

DEPARTMENT OF TRANSPORTATION**National Highway Traffic Safety Administration****49 CFR Part 572**

[Docket No. NHTSA-2004-18865]

RIN 2127-AJ16

Anthropomorphic Test Devices; SID-IIs/FRG Side Impact Crash Test Dummy (SID-IIs With Floating Rib Guide Modifications); 5th Percentile Adult Female

AGENCY: National Highway Traffic Safety Administration (NHTSA), Department of Transportation.

ACTION: Notice of proposed rulemaking (NPRM).

SUMMARY: This document proposes specifications and qualification requirements for a 5th percentile adult female test dummy for use in vehicle side impact tests. NHTSA has published an NPRM to amend Federal Motor Vehicle Safety Standard No. 214, "Side Impact Protection," to add a dynamic pole test to the standard. Under that proposal, all passenger vehicles with a gross vehicle weight rating of 4,536 kilograms (10,000 pounds) or less would have to protect front seat occupants against head, thoracic, abdominal and pelvic injuries in a vehicle-to-pole test simulating a vehicle's side impact crash into narrow fixed objects like telephone poles and trees. Two newly developed anthropomorphic test dummies would be used in the pole test: One representing a 5th percentile adult female, and one representing a 50th percentile adult male. Today's document proposes the specifications and qualification requirements for the 5th percentile female dummy. The 5th percentile adult female crash test dummy allows regulators and researchers to assess the actual performance of vehicles in protecting small-stature occupants in side impacts.

DATES: You should submit your comments early enough to ensure that Docket Management receives them not later than March 8, 2005.

ADDRESSES: You may submit comments (identified by the DOT DMS Docket Number) by any of the following methods:

- Web site: <http://dms.dot.gov>.

Follow the instructions for submitting comments on the DOT electronic docket site.

- Fax: 1-202-493-2251.

- Mail: Docket Management Facility; U.S. Department of Transportation, 400 Seventh Street, SW., Nassif Building,

Room PL-401, Washington, DC 20590-001.

Hand Delivery: Room PL-401 on the plaza level of the Nassif Building, 400 Seventh Street, SW., Washington, DC, between 9 a.m. and 5 p.m., Monday through Friday, except Federal Holidays.

- Federal eRulemaking Portal: Go to <http://www.regulations.gov>. Follow the online instructions for submitting comments.

Instructions: All submissions must include the agency name and docket number or Regulatory Identification Number (RIN) for this rulemaking. For detailed instructions on submitting comments and additional information on the rulemaking process, see the Public Participation heading of the Supplementary Information section of this document. Note that all comments received will be posted without change to <http://dms.dot.gov>, including any personal information provided. Please see the Privacy Act discussion under the Public Participation heading.

Docket: For access to the docket to read background documents or comments received, go to <http://dms.dot.gov> at any time or to Room PL-401 on the plaza level of the Nassif Building, 400 Seventh Street, SW., Washington, DC, between 9 a.m. and 5 p.m., Monday through Friday, except Federal holidays.

FOR FURTHER INFORMATION CONTACT: For non-legal issues, you may call Stan Backaitis, NHTSA Office of Crashworthiness Standards (telephone: (202) 366-4912). For legal issues, you may call Deirdre R. Fujita, NHTSA Office of Chief Counsel ((202) 366-2992). You may send mail to these officials at the National Highway Traffic Safety Administration, 400 Seventh St., SW., Washington, DC, 20590.

SUPPLEMENTARY INFORMATION:**Table of Contents**

- I. Introduction
 - II. Background
 - a. Need for the Dummy
 - b. Development of the FRG
 - III. Description
 - IV. Biofidelity
 - V. Repeatability and Reproducibility
 - a. Component Tests
 - b. Sled Tests
 - 1. 6.7 m/s Flat Wall Test Results.
 - 2. 6.0 m/s Flat Wall Test Results.
 - 3. Abdominal Offset Tests
 - VI. Pelvis Plug
 - VII. Durability
 - VIII. Reversibility for Right and Left Use
 - IX. Directional Impact Sensitivity
 - X. Proposed Calibration Tests
- Rulemaking Analyses and Notices
Public Participation

I. Introduction

This document relates to an NPRM previously issued by NHTSA (69 FR 27990, May 17, 2004; Docket 2004-17694) that proposed to add a vehicle-to-pole test to Federal Motor Vehicle Safety Standard (FMVSS) No. 214, "Side Impact Protection" (49 CFR 571.214). The pole test simulates a vehicle's side impact crash into narrow fixed objects like telephone poles and trees. If adopted as a final rule, the proposed pole test could result in the installation of dynamically deploying side impact air bag systems and other measures to protect front seat occupants against head, thoracic, abdominal and pelvic injuries in side crashes.

In the proposed pole test, an anthropomorphic test dummy representing a 5th percentile adult female is in the front outboard seat on the struck side of the vehicle. Vehicles would have to be certified as complying with an established head injury criterion and with thoracic and pelvic injury criteria developed for the new dummy. The agency has also proposed to use this dummy in FMVSS No. 214's existing moving deformable barrier (MDB) test, which simulates a moving vehicle-to-vehicle "T-bone" type intersection crash. Today's NPRM proposes the specifications and calibration requirements for the 5th percentile adult female test dummy that NHTSA seeks to use in these FMVSS No. 214 crash tests.¹

The development of a small, second-generation side impact dummy was undertaken in 1993 by the Occupant Safety Research Partnership (OSRP), a consortium of the U.S. Council for Automotive Research (USCAR), and dummy manufacturer First Technology Safety Systems (FTSS). (USCAR was formed in 1992 by DaimlerChrysler, Ford and General Motors, as a research and development organization.) The OSRP determined that there was a need for a test dummy that would be better suited to help evaluate the performance of advanced side impact countermeasures, notably air bags, for occupants that are smaller than the 50th percentile size male. The new dummy was named SID-IIs, indicating "SID" as side impact dummy, "II" as second generation, and "s" as small. The SID-IIs dummy was extensively tested in the late 1990s and early 2000 in vehicle crashes by Transport Canada, and to a limited extent by U.S. automobile

¹ The dummy proposed today represents the lower end of the 5th percentile female population range by mass distribution. However, the erect seated height is nearly at the mid point of that population range.

manufacturers and suppliers, and the Insurance Institute for Highway Safety (IIHS).

The dummy specified in today's document is a modified version of the original SID-II dummy. NHTSA's laboratory evaluation of the biofidelity of the SID-II revealed chest displacement transducer mechanical failures and some ribcage and shoulder structural problems. Post test evidence showed that the ribs of the unmodified SID-II did not remain constrained by the rib guides, which allowed their vertical motion during some impactor and sled tests, which in turn raised concerns regarding the structural integrity of the ribs and the deflection potentiometers, as well as the accuracy of the deflection measurements. The agency's Vehicle Research and Test Center (VRTC) modified the dummy's thorax in 2001 to incorporate floating

rib guides to better stabilize the kinematics of the dummy's ribs, and revised the shoulder and its rib guide design to prevent distorting vertical rib motion. The modified dummy proposed today is hereinafter referred to as the "SID-II-FRG," the "FRG" indicating the floating rib guide and other modifications to the dummy.²

The SID-II-FRG has a mass of 44.5 kg (98 pounds) and a seated height of 790 mm (31.1 inches). The dummy is capable of measuring accelerations, deflections and/or forces in the head, thorax, shoulder, abdomen and pelvis body regions. The dummy is described in detail in a NHTSA technical report entitled, "Summary of the NHTSA Evaluation of the SID-II-FRG Side Impact Crash Test Dummy Including Assessment of Durability, Biofidelity, Repeatability, Reproducibility and Directional Sensitivity" (November

2004), and in the PADI document (October 2004), which have been placed in the docket for today's NPRM. (A number of technical reports providing further test details on the dummy, such as its repeatability and reproducibility, have also been placed in docket 17694, *supra*.)

II. Background

a. Need for the Dummy

Data from the 1990–2001 National Automotive Sampling System (NASS) Crashworthiness Data System (CDC) indicate a need for a dummy that has the capability of predicting the risk of injury to a segment of small-statured vehicle occupants in side crashes. Table 1 shows the injury distribution of the estimated target population less than 65 inches (in) in stature in all types of side impact crashes between 12 and 25 mph delta V.

TABLE 1.—U.S. MOTOR VEHICLE SMALL STATURE ADULT OCCUPANT POPULATION INJURY SEVERITY DISTRIBUTION IN SIDE CRASHES

[For delta-V of 12–25 mph]

Body region	MAIS 1	MAIS 2	MAIS 3	MAIS 4	MAIS 5	Fatality	Total
Head and Face	6706	1864	99	142	163	527	9049
Thorax	4377	295	1213	671	11	446	7094
Abdomen	264	86	20	112	27	96	670
Pelvis	0	0	123	0	0	6	136

The 1990–2001 NASS/CDS data also indicate that there are differences in the body region distribution of serious injuries between small and medium stature occupants in these side collisions. The data suggests that small stature occupants have a higher proportion of head, abdominal and pelvic injuries than medium stature occupants, and a lower proportion of chest injuries (Samaha *et al.*, "NHTSA Side Impact Research: Motivation for Upgraded Test Procedures," 18th ESV Conference Proceedings). The agency believes that, in addition to a 50th percentile adult male dummy, use of a small-statured dummy in side impact testing would better represent the population at-risk in side impacts and substantially enhance protection for small adult occupants.

b. Development of the FRG

NHTSA began an extensive evaluation of the SID-II in 2000. The biofidelity of the dummy was assessed in component and sled testing that examined the ability of the dummy to load a vehicle

as a cadaver does, and to replicate cadaver responses that best predict injury potential. Our finding from the sled tests was that a 8.9 m/s test was too severe to assess the durability and other characteristics of the dummy. Some of the 8.9 m/s tests resulted in damaged ribs, bent potentiometer shafts and crushed potentiometer housings. NHTSA's examination of the causes of the damage to the SID-II revealed the rib guides for the shoulder, thorax and abdomen ribs did not sufficiently prevent vertical movement of the ribs ("rib jump"), and that the dummy's rib stops allowed excessive deflection of the ribs. The observed damage raised concerns regarding the structural integrity of the ribs and the deflection measuring potentiometers, as well as the accuracy of the dummy's deflection measurements, particularly for a dummy that could possibly be used for regulatory purposes.

After extensive evaluation of these failures, the agency began incremental modifications of the dummy to improve the dummy's durability.³ Because

vertical movement of the ribs was deemed to be one of the causes for the damage to the thorax and abdomen regions of the dummy, VRTC developed the "floating rib guide" system, which prevents the compressed ribs from leaving the outside perimeter of the rib guides. The new guides "float" with the ribs as they expand in the anterior-posterior direction during the compression process, and thereby prevent rib jump. The FRG design includes deeper rib guides than on the unmodified SID-II dummy in both the thorax and abdomen regions. During deflection, the ribs contact carbon fiber cover plates affixed to the rib guides in the front and rear of the dummy. Guide pins and springs allow the rib guides to expand outwards, thus maintaining the ribs within the outside perimeter of the rib guides during the deflection event.

In addition, the shoulder rib guide of the dummy was reshaped and deepened beyond the front edge of the shoulder rib to keep the shoulder rib from moving vertically during its compression. The damping material of the shoulder rib

²NHTSA has placed in docket 17694 a technical report entitled, "Development of the SID-II-FRG," Rhule and Hagedorn, November 2003, which

describes the need for and extent and purpose of the FRG modifications.

³The technical report "Development of the SID-II-FRG," *supra*, describes the history and

evaluation of the design changes made to the SID-II dummy between the fall of 2000 and the spring of 2003.

assembly was made thinner and spanned the entire width of the steel band. The FRG design used vinyl-coated aluminum rib stops to reduce excessive rib deflection, as excessive deflection was also one of the causes of bent potentiometer shafts and crushed potentiometer housings. To further protect the instrumentation, the new rib stops were located to reduce the maximum lateral rib deflection from 69 mm to 60 mm.⁴

NHTSA conducted sled tests and air bag out-of-position tests comparing the durability of the FRG dummy to an unmodified SID-IIs dummy. The tests showed that the SID-IIsFRG design prevented rib jump and potentiometer damage that were evident in the unmodified dummy. These results are discussed in section VII of this preamble.

NHTSA also conducted tests to compare the measurement capabilities and response levels of the SID-IIsFRG to the SID-IIs dummy ("Summary of the NHTSA Evaluation of the SID-IIsFRG Side Impact Crash Test Dummy Including Assessment of Durability, Biofidelity, Repeatability, Reproducibility and Directional Sensitivity" (November 2004), *supra*.) The SID-IIsFRG displayed comparable measurements in all conditions except for high-speed flat wall sled tests and high-speed purely lateral probe impacts to the upper torso of the dummy. During these tests, the SID-IIsFRG dummy exhibited smaller rib deflections (10 percent smaller), but larger thorax load wall forces (17 percent) and T1 accelerations (20 percent larger) than the SID-IIs. Similar trends of reduced chest deflections between SID-IIs FRG and SID-IIs were reported by Transport Canada in a set of paired side impact crash tests of two identical Camry vehicles in limited vehicle crash tests ("SID-IIs Response in Side Impact Testing," Tylko and Dalmotas, SAE Paper No. 2004-01-0350).

NHTSA also conducted two pairs of repeat crash tests comparing the SID-IIsFRG and the SID-IIs ("Development of the SID-IIsFRG," *supra*). The two tests included repeat oblique pole impacts with a dummy in the driver seat of a 2002 Ford Explorer. One of the tests was with the SID-IIsFRG (test number v4563), and the other was with the SID-

IIs (test number v4601). NHTSA also conducted a pair of repeat tests using the Side New Car Assessment Program (NCAP) protocol⁵ with a 2001 Ford Focus, the first with a SID-IIsFRG in the driver's seat and an unmodified SID-IIs in the rear left passenger seat (test number v4576), and the second with an unmodified SID-IIs in the driver's seat and a SID-IIsFRG in the rear left passenger seat (test number v4562).

In this limited set of repeat crash tests by the agency, the results indicated that maximum thorax and abdomen deflections for the SID-IIsFRG, for the most part, were less than those of the SID-IIs. The limited crash test results appear to be consistent in trend with impactor and sled test results.

III. Description

A technical report and other materials describing the SID-IIsFRG in detail have been placed in the docket for today's NPRM (Docket No. 18865) and in Docket No. 17694. The specifications for the proposed SID-IIsFRG consist of: (a) A drawing package containing all of the technical details of the dummy; (b) a parts list; and (c) a manual containing procedures for assembly, disassembly, and inspection (PADI) of dummy components. These materials have been placed in Docket No. 18865. These drawings and specifications ensure that the dummies are uniform in design and construction. The certification tests proposed in this NPRM would assure that the dummy responses are within the established qualification corridors and further validate the uniformity of dummy assembly, structural integrity, and adequacy of instrumentation. As a result, the repeatability and reproducibility of the dummy's performance in dynamic testing would be ensured.

Drawings and specifications for the SID-IIsFRG are available for examination in the NHTSA docket section. Copies of those materials and the user manual may also be obtained from Leet-Melbrook, Division of New RT, 18810 Woodfield Road, Gaithersburg, MD 20879, tel. (301) 670-0090.

Anthropometry and mass of the SID-IIsFRG are based on the Hybrid III 5th percentile frontal female dummy and also generally match the size and weight of a 12- to 13-year-old child. The head and neck designs are based on the

Hybrid III 5th percentile female dummy. The legs are Hybrid III 5th percentile female design available also with femur load cell instrumentation.

At the same time, the dummy's torso construction is distinctly different from other Hybrid III series of dummies as the SID-IIsFRG design is particularly oriented for assessing the potential for side impact injury. The dummy's upper torso is made up of a rigid metallic spine to which six steel bands lined with bonded polymer damping material are attached to simulate the impact performance of the human shoulder (1 rib), thorax (3 ribs) and abdomen (2 ribs). Linear potentiometers are attached from the ribs to the spine for compression measurements. Provisions are available for mounting tri-axial accelerometer packs to the spine at T₁ and T₁₂ and at each rib.⁶ Replaceable foam pads are secured directly to the ribs and a neoprene jacket covers the complete chest assembly. The upper torso accommodates the attachment of the neck at the upper end and the lumbar spine at the lower end.

A stub arm on the impacted side is attached to the lateral aspect of the shoulder through a three-axis load cell. Tri-axial accelerometer packs can also be installed at the shoulder and at the upper and lower parts of the stub arm for side airbag inflation injury assessment.

The dummy's pelvis is a machined assembly with detachable hard urethane iliac wings at each side and covered by vinyl flesh. The pelvis design is shaped in a seated human-like posture and allows the attachment of the lumbar spine at its top and the legs at the left and right sides. The pelvis can be impacted from either side without any change in hardware. Replaceable foam crush plugs at the hip joint are used to control the lateral pelvis response. The pelvis design allows the measurement of impact loads at the acetabulum and iliac wing as well as accelerations at the pelvis center of gravity (c.g.).

The external dimension and assembly weight of the SID-IIsFRG are shown in Table 3 below. Additional dimensional information may be found in the September 2004 Technical Drawings and Specification package in Docket No. 18865.

⁶ T₁—sensor location on the dummy's thoracic spine equivalent to the first cervical on the human thoracic spine. T₁₂—sensor location on the dummy's thoracic spine equivalent to the 12th cervical on the human thoracic spine.

⁴ The FRG design also incorporated other changes, such as the use of a cable tie to attach the dummy's thorax and abdomen pads to the ribs, and the removal of ¼ inch from the top of the abdomen pad to avoid interference with the thorax pad.

⁵ In the agency's New Car Assessment Program (NCAP), the FMVSS No. 214 moving deformable barrier impacts the vehicle at 38.5 miles per hour.

TABLE 3.—EXTERNAL DIMENSIONS AND ASSEMBLY WEIGHTS OF THE SID-IIsFRG

External dimensions			Assembly weights		
Dimension	(in)	(cm)	Segment mass	(lb)	(kg)
Erect Sitting Height	31.0	78.7	Head	8.16	3.71
Chest Circumference w/Jacket	34.5	87.6	Neck	2.00	0.91
Chest Depth	8.0	20.3	Upper Torso	26.10	11.86
Shoulder Width	13.6	34.5	Lower Torso	26.82	12.19
H-Point Height	3.4	8.6	Stub Arm	2.00	0.91
Buttock Popliteal Length	16.9	42.9	Upper Legs	13.80	6.26
Buttock to Knee Length	20.8	52.7	Lower Legs/Feet	17.90	8.12
Knee to Floor Height	15.8	40.1	Total	96.78	43.90

The SID-IIsFRG is instrumented to assess injury to the head, neck, shoulder, thorax, abdomen, pelvis, stub arm and lower extremities. A complete list of the instrumentation available for this dummy is shown in drawing 180-0000, sheet 3 of 6. Table 3—External Dimensions and Assembly.

IV. Biofidelity

Biofidelity is a measure of how well a test device duplicates the responses of a human in an impact. Two methods are currently available for assessing the biofidelity of a dummy in side impact testing. The first is a procedure of the International Organization of Standardization (ISO), referred to as the ISO TR 9790 methodology (Irwin *et al.*, “Guidelines for Assessing the Biofidelity of Side Impact Dummies of Various Sizes and Ages,” 2002 Stapp Car Crash Journal, Vol. 46, #2002-22-0016). It determines the biofidelity of a dummy by how well the dummy’s body segment and/or subsystem impact responses replicate cadaver responses in defined impact environments. The second is the Biofidelity Ranking System developed by NHTSA (Rhule H., *et al.*, 2002 Stapp Car Crash Journal, Vol. 46, p. 477, “Development of a New Biofidelity Ranking System for Anthropomorphic Test Devices”). The SID-IIsFRG was evaluated by both methods.

Assessment of the SID-IIsFRG by the ISO Biofidelity Classification System

The biofidelity requirements defined in ISO TR 9790 are based on two types of head drop tests, three types of lateral neck bending tests, four types of shoulder impact tests, six types of lateral thoracic tests, five abdominal test conditions and thirteen lateral pelvis impact tests. The measured response values are assessed on their fit to the established cadaver response corridors. A value of 10 is given if the dummy’s segment response is completely within the boundaries of the cadaver response corridor. A value of 5 is given if the

most important portion of the dummy’s segment response lies within one corridor width outside of the specified performance boundaries and in others, such as for unusually complex shapes of response curves, by group judgment of a group of biomechanical experts on the fit of the data. A value of zero is given if neither of the above conditions is met.

The overall dummy’s biofidelity is found by weighted average of the scores of different body regions. Five classifications indicate the degree of biofidelity of the overall dummy rating. A dummy with a rating above 8.6 is classified as excellent, 6.5 to 8.6 as good, 4.4 to 6.5 as fair, 2.6 to 4.4 as marginal, and below 2.6 as unacceptable.

The ISO methodology was used by OSRP members to evaluate the SID-IIsFRG in September 2004 (“Technical Summary of OSRP-SID IIs Upgrade,” September 2004). A copy of the document is in the docket for this NPRM. As shown in Table 4, the SID-IIsFRG received an ISO Biofidelity rating of 5.9, which corresponds to a “fair” classification. Scherer *et al.* had rated the SID-IIs Beta Prototype dummy a rating of 7.0, placing it in the ISO classification of “good.”⁷

TABLE 4.—SUMMARY OF ISO BIOFIDELITY FOR SID-IIs AND SID-IIsFRG

Body Segment	ISO Biofidelity Classification	
	SID-IIs	SID-IIsFRG
Head	7.5	7.5
Neck	5.2	4.8
Shoulder	6.2	5.1
Thorax	7.8	6.5
Abdomen	8.8	5.7
Pelvis	5.7	5.3
Overall	7.0	5.9

⁷ Scherer, *et al.*, “SID IIs Beta+ Prototype Dummy Biomechanical Responses,” 1998, SAE 983151.

The OSRP-developed ISO ratings for the SID-IIs and SID-IIsFRG dummies compare favorably with other side impact dummies. The overall ES-2re⁸ dummy’s biofidelity rating was determined to be 4.6, while the SID (49 CFR Part 572 Subpart M) and EuroSID-1 dummies received ratings of 2.3 and 4.4,⁹ respectively. The SID-HIII received an overall rating of 3.8 (63 FR 41468).

Assessment by the NHTSA Biofidelity Ranking System

The NHTSA method of evaluating the biofidelity of a dummy determines the biofidelity based on two assessment measures: (a) The ability of a dummy to load the relevant contact surfaces as a cadaver does (termed “External Biofidelity”); and (b) the ability of a dummy to replicate those cadaver responses that best predict injury potential (“Internal Biofidelity”). This ranking system evaluates the dummy’s ability to replicate the cadaver loading responses at the whole body level, and how that body replicates the loading of interfacing external structures.

Similar to the ISO TR 9790 biofidelity rating system, the NHTSA ranking system is based on a comparison between cadaver and dummy responses in head drop tests, thorax and shoulder pendulum tests, and whole body sled tests including abdominal and pelvic offset test conditions. Each test condition is assigned a weighting factor, based on the number of human subjects tested, to form a biomechanical response corridor and the relevance of the biofidelity test to the intended test environment. For each response requirement, the cumulative variance of the dummy response relative to the

⁸ The ES-2re dummy is a 50th percentile European designed adult male side impact crash test dummy that the agency has proposed to use in the proposed upgrade of FMVSS No. 214 (69 FR 27990, *supra*).

⁹ Byrnes, *et al.*, “ES-2 Dummy Biomechanical Responses,” 2002, Stapp Car Crash Journal, Vol. 46, #2002-22-0014, p. 353.

mean cadaver response (DCV), and the cumulative variance of the mean cadaver response relative to the mean plus one standard deviation (CCV) are calculated. The ratio of DCV/CCV expresses how well the dummy response duplicates the mean cadaver response. A smaller ratio indicates better biofidelity.

Although this method does not establish an "absolute" ranking scale, the ranks provide a relative sense of the "number of standard deviations" the dummy's responses are away from the mean human response. If the dummy biofidelity ranking is below two, the

dummy is behaving similar to the human cadaver. The evaluation methodology provides a comparison of both dummy response to cadaver response as well as a comparison of two or more dummies.

Comparison Between SID-IIsFRG, ES-2re and SID-HIII Dummies

Tables 5 and 6 were constructed to provide a comparison of external and internal biofidelities between the SID-IIsFRG, the ES-2re and the SID-HIII (Part 572 Subpart M) 50th percentile male side impact dummies.¹⁰

The data in Table 5 indicate that the SID-IIsFRG dummy has comparable Overall External Biofidelity with the ES-2re dummy and has better biofidelity than the SID-HIII dummy. At the body segment level, the SID-IIsFRG produces better External Biofidelity ranks than the ES-2re in the Head/Neck, Thorax and Abdomen and worse ranks than the ES-2re in the Shoulder and Pelvis. The SID-IIsFRG produces better External Biofidelity ranks than the SID-HIII in all body regions except the Head/Neck.

TABLE 5.—EXTERNAL BIOFIDELITY RANKS

External biofidelity	SID-IIs FRG	ES-2re	SID-HIII
Overall Rank	2.5	2.6	3.8
Head/Neck Rank	1.8	3.7	1.0
Shoulder Rank	2.6	1.4	5.1
Thorax Rank	2.8	2.9	6.1
Abdomen Rank	2.4	2.6	3.0
Pelvis Rank	3.0	2.7	3.8

Table 6 provides a comparison of the Internal Biofidelity ranks of the three dummies. The data indicate that the SID-IIsFRG Overall Biofidelity rank is

better than those of the two 50th percentile male dummies, both with and without the abdomen being included in the biofidelity ranking calculations. All

body region Internal Biofidelity ranks of the SID-IIsFRG are better than, or comparable to, those of the ES-2re and SID-HIII.

TABLE 6.—INTERNAL BIOFIDELITY RANKS

Internal biofidelity	SID-IIs (FRG)	ES-2re	SID-HIII
Overall Rank with abdomen	1.5	n/a	n/a
Overall Rank without abdomen	1.3	1.6	1.9
Head Rank	0.4	1.0	1.1
Thorax Rank	¹ 1.8	¹ 1.9	² 2.2
Abdomen Rank	2.0	n/a	n/a
Pelvis Rank	³ 1.6	³ 2.0	³ 2.5

n/a—Not applicable.

¹ Rib defl & T-12 lat accel.

² TTI.

³ Pelvis lateral acceleration.

Based on the Overall External and Internal Biofidelity ranks, the SID-IIsFRG and the ES-2re dummies were found to be nearly equivalent and are lower than the SID-HIII dummy.¹¹

Based on the information from the biofidelity assessment, the agency tentatively concludes that the SID-IIsFRG is well suited for assessing the risk of injury to the small size occupant segment.

V. Repeatability and Reproducibility

A dummy's repeatability and reproducibility analysis is typically based on component tests and a series

of sled tests. In the tests, the impact input is carefully controlled to minimize the variability of external effects on the dummy's response. Component tests are better controlled, and thus produce more reliable estimates of the dummy's repeatability and reproducibility than is possible in sled and vehicle tests. Component tests are also needed to certify the dummy's performance relative to the established response corridors for each major body segment. That is, if the dummy's component is or becomes deficient, the certification test will identify to the user that the component will not respond

properly in impact tests, and that a replacement of parts should precede further testing. Sled tests, on the other hand, offer a method of efficiently evaluating the dummy as a complete system in an environment much like a vehicle test. Sled tests are needed to establish the consistency of the dummy's kinematics, its impact response as an assembly, and the integrity of the dummy's structure and instrumentation under controlled and representative crash environment test conditions.

Two SID-IIsFRG dummies were tested and exposed to both component

¹⁰ The SID-IIsFRG and the ES-2re ranks were calculated primarily on data from sled tests at the Medical College of Wisconsin and impactor tests at

VRTC. The SID-HIII rankings were calculated based on data obtained in VRTC tests.

¹¹ As noted in the Technical Report for the SID-IIsFRG, NHTSA also compared the biofidelities of

the SID-IIs and the SID-IIsFRG by the NHTSA method and found that the dummy responses are substantially comparable to the mean cadaver responses and to each other.

and sled test conditions multiple times to determine the dummy's ability to respond consistently. The evaluation of the SID-IIsFRG during these tests is described in the following technical reports: "Repeatability and Reproducibility Analysis of the SID-IIsFRG Dummy in the Sled Test Environment," February 2004; and "Repeatability and Reproducibility Analysis of the SID-IIsFRG Dummy in the Certification Test Environment," March 2004 (see NHTSA Docket No. 17694) and "Summary of the NHTSA Evaluation of the SID-IIsFRG Side Impact Crash Test Dummy Including Assessment of Durability, Biofidelity, Repeatability, Reproducibility and Directional Sensitivity" (Docket No. 18865). The following discussion summarizes the finding of these reports.

a. Component Tests

Component tests were conducted on head, neck, shoulder, thorax with arm, thorax without arm, abdomen, and pelvis body regions. The tests are described in Section X of this preamble, "Proposed certification tests." The repeatability assessment was made using Coefficient of Variation (CV) in percentage as a measure. A CV value of less than 5 percent is considered excellent, 5–8 percent good, 8–10 percent acceptable, and above 10 percent unacceptable.¹² The reproducibility was established by comparing the percent CV of two different dummies' combined responses.

The results of the component repeatability tests indicate "excellent" repeatability for the SID-IIsFRG dummy for all components except for the thorax with arm, which has a "good" rating.

The results of the component tests generally indicated "excellent" to "good" reproducibility for the dummy for all components. The pelvis lateral acceleration was the only elevated reproducibility response at a CV of 9.1 ("acceptable"). The agency believes that some of this elevated variability was due to inconsistent force-deflection characteristics of the pelvis plug. As described in Section VI of this preamble, we believe that the variability of the pelvis lateral acceleration can be improved by incorporating force-deflection limits for the pelvis plug into the specifications for the test dummy. Today's NPRM proposes such performance requirements in Section VI of this preamble.

b. Sled Tests

The sled tests were conducted on a Hyge-type sled system, on which a

bench seat and impact load wall were mounted. During the test, the SID-IIsFRG slid down the bench seat and impacted the rigid load wall. The first set of tests was conducted with a flat load wall at 6.7 meters/second (m/s). The selected impact speed reflected one of the impact environments in agency-sponsored PMHS (post-mortem human subject) tests that provided a partial basis for the development of biomechanical performance corridors. However, in this test series, the shoulder rib was found to have bottomed out against the rib stops.

In order to produce a more suitable test condition in the range of intensity that would be expected in a crash test, the sled speed was reduced and a second series of three tests was conducted (with a flat wall) at 6.0 m/s. The dummy's arm was positioned down in these flat wall tests. The third series of tests was also conducted at 6.0 m/s with a 101 mm abdomen offset block on the load wall ("abdominal offset tests"), and with the dummy's arm in the up orientation. The 101 mm offset block was oriented such that it would impact the abdomen only, above the pelvis and below the lower thoracic rib. The objective of the abdomen offset tests was to provide a test environment with severe loading of the abdominal region.

1. 6.7 m/s Flat Wall Test Results

Generally the responses in the 6.7 m/s flat wall sled tests displayed either excellent or good repeatability in all measurements, except for concerns that the SID-IIsFRG dummy's shoulder rib was at or very close to reaching the maximum available displacement.¹³ The SID-IIsFRG dummies also generally demonstrated excellent or good reproducibility for measurements proposed for incorporation into FMVSS No. 214 (69 FR 27990, *supra*).

2. 6.0 m/s Flat Wall Test Results

The dummies exhibited overall excellent or good repeatability in all injury indicating measurements in this test series. However, the resultant pelvis acceleration of dummy serial number (S/N) #56 had a marginally unacceptable CV of = 10.9%. NHTSA notes that the CV for resultant pelvis acceleration was calculated using the highest peak value within the data trace, which could be either the first or the second peak. NHTSA believes that the magnitude of the peak, and whether it

was the first or the second peak during the impact, was determined by the stiffness characteristic of the pelvis plugs used in the tests. An excessively stiff plug would be the cause for high first peaks usually occurring within the first 5 ms in certification tests, while a softer plug would favor the predominance of a higher second peak, occurring in the latter part of the impact event, that is later than 5 ms from time of impact. The agency believes that the performance requirements specified in today's document for the pelvis plug will prevent use of excessively stiff plugs, and that softer plugs will result in a more consistent pelvis response measurement.

3. Abdominal Offset Tests

The dummies demonstrated excellent or good repeatability and reproducibility in all of the abdominal offset test measurements, except that the CV of the peak resultant pelvis acceleration for one of the dummies was 10.5%. NHTSA believes that the elevated CV was due to the variability of the pelvis plug response.

Based on the testing of the SID-IIsFRG dummy, the agency tentatively concludes that the repeatability and reproducibility of the SID-IIsFRG's responses establishes the suitability for use in the agency's side impact test programs.

VI. Pelvis Plug

The stiffness limits of the pelvis plug proposed in this NPRM affect mostly the peak pelvic acceleration, peak acetabulum force, and peak iliac force levels of the dummy, as well as the maximum force measured by the impacting pendulum. In the pelvis certification test of the dummy, the pendulum impact probe is centered on the pelvis plug that is mounted within the pelvis flesh cavity in front of and in line with the acetabulum load cell's longitudinal axis either at the right or left H-points of the dummy (depending on the side of the dummy to be impacted). The original recommended practice was to require that the pelvis plug be discarded after each impact.

In agency testing, NHTSA observed that some of the data traces of the dummy's pelvis acceleration showed an inconsistent first peak in the data trace that was generated by the probe's impact. ("Summary of the NHTSA Evaluation of the SID-IIsFRG Side Impact Crash Test Dummy Including Assessment of Durability, Biofidelity, Repeatability, Reproducibility and Directional Sensitivity" (November 2004), *supra*.) Agency evaluation showed that the inconsistency of the

¹³ Because the shoulder rib almost always reached maximum stroke and contacted the rib stops in this 6.7 m/s test, the agency did not assess the repeatability or reproducibility of the upper spine (T₁) acceleration measurements or the shoulder rib deflection in this test.

¹² ISO/TC22/SC12/WG5.

first peak acceleration response was caused by variability of the crush characteristics of the pelvis plugs (*i.e.*, variability of the resistance force during compression) rather than by other characteristics of the dummy. The plug as originally specified for the SID-IIs provided practically no control over its stiffness characteristics.

Agency evaluation indicated that control of the crush characteristics of the pelvis plug would significantly improve the consistency of all of the dummy's pelvis responses as well as the force values measured by the impact probe. Based on an evaluation of plugs with a variety of force deflection characteristics, NHTSA has developed a force-displacement corridor for the pelvis plug that assures less variability of the pelvis acceleration response. As a result, a test procedure was developed for measuring the force-displacement characteristics of the plugs. The proposed procedure evaluates a plug by quasi-statically compressing it to a deflection range between 22 and 25 mm and a corresponding resistance force between 1920 and 2160 Newtons (N) at minimum compression and 2000 to 2240 N at maximum compression.¹⁴ (See Drawing—Plug Pelvis #180–4450.)¹⁵ Only plugs that meet the specified force levels at prescribed compression would be certified for use in a side impact test using the dummy.

A plug is certified after passing the compression test. The agency anticipates that users may either purchase the plugs commercially or certify the plugs themselves. For pelvis calibration, the certified plug is inserted into the pelvis cavity of the dummy and the dummy's pelvis is calibrated according to the proposed Part 572 test procedure. It should be noted that the pelvis plugs can only be used once per either vehicle crash test or pelvis certification application. After the dummy's pelvis is calibrated, the plug must be discarded. A new certified plug is inserted into the pelvis cavity of the dummy for every crash test incorporating the SID-IIsFRG. Carefully controlled and certified crush characteristics of the plugs will assure that their use will produce consistent and reliable pelvis response in the impact environment.

¹⁴ The proposed values may slightly change for purposes of a final rule as new data on plug deformation characteristics become available.

¹⁵ The procedure and proposed force-displacement requirements are specified on this drawing for the pelvis plug, which is part of the drawing package for the SID-IIsFRG dummy.

VII. Durability

NHTSA examined the durability of the SID-IIs dummy in the context of the potential use of the dummy for regulatory purposes. In testing under FMVSS compliance and NHTSA's consumer information programs, test dummies are exposed to a wide range of side crash conditions. They may be tested with vehicles with highly advanced crashworthiness technologies and with vehicles that lack adequate structure and/or features that effectively mitigate the crash forces. A crash test dummy has to have sufficient durability to maintain its structural integrity and measurement ability throughout this range of potential test conditions.

Background

The agency's assessment of the SID-IIs began with an evaluation of the dynamic performance of the dummy in sled tests conducted at 8.9 m/s and 6.7 m/s with various impact surfaces.¹⁶ These test velocities were chosen to replicate agency-sponsored PMHS impacts in sled tests involving 8.9 m/s and 6.7 m/s changes in velocity.¹⁷ Those NHTSA PMHS tests had approximated some of the biomechanical tests performed in the 1980s and 1990s by Wayne State University, University of Michigan Transportation Research Institute and others that were used to develop the ISO 9790 impact response corridors for assessing the biofidelity of test dummies.¹⁸ The biomechanical data from the PMHS tests enabled NHTSA to develop the injury criteria that would predict the risk of injury in side impact crashes.¹⁹

One finding of the sled tests was that the 8.9 m/s test was too severe to assess the durability and other characteristics of the dummy. Impact tests of the SID-IIs dummy into a 4-inch padded 103 kPa flat wall at 8.9 m/s indicated abdominal rib deflections as high as 62 mm. Impacts into a 3-inch 400 kPa padded flat wall at 8.9 m/s produced abdominal rib deflections bordering 70 mm, including an indication of flat topping. (Flat topping is an indication that the

dummy's rib deflection mechanism is either binding or reaching the end of the available stroke, and consequently, the dummy's abdomen is not responding correctly to the load from the intruding side structure. When flat topping occurs, the potentiometer ceases to produce useful deflection measurements, and in some instances experiences physical damage.) Some of these abdominal deflections were in excess of predicting a probability of a 50% risk of AIS 4+ abdominal injury.

On the other hand, NHTSA found that the 6.7 m/s sled test was more appropriate for evaluating the durability of the dummy. Sled impacts into a padded wall at 6.7 m/s yielded maximum abdominal rib deflections of approximately 45 mm with 103 kPa padding and 61 mm with 400 kPa padding. Inasmuch as the 61 mm abdominal rib deflection was just above the 25% probability of AIS 4+ injury level and the deflection data trace contained no indication of flat topping or other signal irregularities, the 6.7 m/s impact speed was selected as an impact intensity that the dummy must withstand without structural damage and instrumentation failures.²⁰ The SID-IIs did not show durability problems in the 6.7 m/s sled tests into a padded wall.

Follow On Tests

Follow on tests, however, indicated a possible durability problem with the SID-IIs in 6.7 m/s sled tests using a rigid wall with a 101 mm abdominal offset. The agency conducted the tests to replicate biomechanical sled test impact configurations previously reported by Maltese *et al.* ("Response Corridors of Human Surrogates in Lateral Impacts," *supra*). These abdominal offset tests significantly damaged the dummy. Damage in some of the tests included deformed abdominal ribs, bent abdominal potentiometer shafts, and/or gouged damping material. Further analysis of the sled tests and pendulum tests with the SID-IIs suggested that either vertical motion of the ribs and/or excessive rib compression caused the damage to the ribs and the potentiometers.

²⁰ The durability tests were conducted at 6.7 m/s, whereas the tests assessing the repeatability and reproducibility of the dummy were conducted at 6.0 m/s. The 6.0 m/s test speed was appropriate for assessing the dummy's repeatability and reproducibility because tests at that velocity produce dummy responses that are seen in crash tests, and approach the limits of the injury criteria associated with the dummy at a 25% of AIS 4+ injury. Durability tests are conducted at a higher velocity to "overload" the dummy, to subject it to conditions that could give rise to possible durability problems in automotive crash test environments.

¹⁶ See "Development of the SID-IIs FRG," *supra*.

¹⁷ Maltese *et al.*, "Response Corridors of Human Surrogates in Lateral Impacts," Technical Paper 2002-22-0017, Proceedings, 46th Stapp Car Crash Conference.

¹⁸ ISO/TC 22/SC 12/WG 5, document 645.

¹⁹ Among other findings, NHTSA determined that the SID-IIs dummy, experiencing thoracic rib deflections of 41 mm, would predict a 25% probability of AIS 4+ thorax injury, and at 56 mm of rib deflection, a 50% probability of AIS 4+ injury. Further, an abdominal deflection of 59 mm produces a 25% of risk of AIS4+, and at 67 mm, a 50% probability of AIS 4+ abdominal injury. "Injury Criteria for Side Impact Dummies" (NHTSA docket 17694-12).

These failures prompted NHTSA's Vehicle Research and Test Center to search for ways to improve the abdominal rib response through a redesign of the existing SID-IIs rib guides, including subsequent introduction of floating rib guides. The agency wanted to make certain that the SID-IIs dummy was sufficiently robust and durable in all foreseeable impact environments. Modifications of the SID-IIs dummy leading to the SID-IIsFRG design are discussed in Section IIb of this preamble. The FRG design modifications have prevented damage to the dummy even under very severe loading conditions. Three test series are summarized below.

In the first series, NHTSA conducted two sets of seven 6.7 m/s sled tests to evaluate the durability of the SID-IIsFRG. They included rigid wall thorax and rigid 101 mm abdomen offset impact configurations. In contrast to previous testing of an unmodified SID-IIs dummy to these test configurations, the SID-IIsFRG experienced no damage either to the potentiometers or any of the thoracic and abdominal ribs. There were no losses of or discontinuities in the potentiometer data signals. ("Development of the SID-IIs FRG," Section 7.3, *supra*. Other durability tests are also discussed in this report.)

In another series evaluating the FRG design, the agency tested the durability of the FRG revised shoulder rib (containing a wider rib damping material area) and redesigned shoulder rib guide. An out-of-position side air bag test in the passenger side of a 2000 BMW 528i was selected because that test had resulted in damage to both the shoulder rib and shoulder potentiometer of an unmodified SID-IIs. In the tests, the dummy was positioned directly against the side air bag, as outlined by the Technical Working Group (Lund, A., Chairman of the Side Air Bag Out-of-Position Injury Technical Working Group, "Recommended Procedures for Evaluating Occupant Injury Risk from Deploying Side Airbags," August 2000). The test conditions allowed the side air bag to contact the thoracic and abdominal ribs with an upward component. In these tests, the SID-IIsFRG had none of the damage to the shoulder rib and shoulder potentiometer that was observed in the unmodified SID-IIs. The shoulder rib guide design prevented the rib from jumping out of the rib guide, thus eliminating permanent rib distortion and damaging the potentiometer. "Development of the SID-IIs FRG," Section 7.4.

In a third series of durability pendulum tests, rigidly fixed thoraxes of the unmodified SID-IIs and the SID-

IIsFRG, with their jackets off, were tested in a perpendicular, 15 degree upward impact configuration at a velocity of 2.84 m/s (6.4 miles per hour). When subjected to a localized pendulum impact centered on #2 thoracic rib, the potentiometer shafts of the unmodified SID-IIs bent, and potentiometer bushings pulled out of the potentiometer bearing assemblies. *Id.*, Section 7.9. In contrast, the SID-IIsFRG potentiometer measured rib deflections while sustaining no structural damage.

In sum, the FRG design has significantly improved the durability of the SID-IIs dummy and made it useful for the assessment of risk injury in the most severe automotive impact environments.²¹

VIII. Reversibility for Right and Left Use

The SID-IIsFRG is designed to have equivalent performance when impacted from either the left or right side. However, most agency tests have been left side impacts. To convert the dummy's impact side from left to right side and vice versa, the entire dummy's thorax, abdomen, and shoulder structure, upon disengagement of the neck and of the lumbar spine at the lower torso interfaces, is rotated as a unit around the vertical axis with respect to the neck and the lumbar spine without any further modifications. Limited agency testing of the dummy converted from left to right side impact indicated complete compliance to the calibration corridors, except for the head response being below the lower calibration limit by 1g. The agency does not believe this to be a problem, since the head used in this test was a single test of a dummy build with consideration for only left side impact. Once the calibration specifications are proposed for right and left side impacts, the vehicle manufacturers should have no problem manufacturing the heads complying to the calibration specifications for both right and left side impacts.

The method for reversing the dummy for use in either left-or right-side impacts is discussed in the PADI document for the SID-IIsFRG dummy.

IX. Directional Impact Sensitivity

Limited NHTSA tests indicate that the SID-IIsFRG dummy's thoracic and abdominal rib deflection and upper spine (T₀₁) and lower spine (T₁₂) acceleration measurements exhibit a

degree of directional sensitivity depending on pendulum impact angle and velocity. The agency conducted pendulum oblique impact tests at 4.3 m/s on the dummy's shoulder, thorax, and abdomen. Tests were conducted on the SID-IIsFRG at 4.3 m/s with the dummy's midsagittal plane oriented perpendicular to the trajectory of the impact probe, and at an oblique frontal angle of +30 degrees, +15 degrees and at -15 degrees posterior to the lateral plane of the dummy. The dummy in those tests measured reduced shoulder, thoracic and abdominal rib deflections in the +30 and +15 degrees oblique impacts when compared to pure lateral impacts. The thoracic reduction ratios were 0.78 and 0.79 for oblique angles of +15 and -15 degrees. Similar reduction ratios in deflection are experienced in abdominal and shoulder impacts tests in +30 degree impacts, but the ratios reduce as the angle decreases to +15 degrees. The SID-IIsFRG dummy's peak Y (lateral) acceleration of the upper spine and lower spines in 4.3 m/s oblique impacts show lower levels of directional sensitivity as compared to the deflection measurements, except for the elevated ratios of the upper spine in abdominal impact at +15 degrees (1.27) and higher ratios of lower spine (3.22) and upper spine (2.20) accelerations in +30 degree impacts.

To NHTSA's knowledge, biomechanical data on whether and the degree to which human cadavers experience directional sensitivity in oblique impacts do not exist. It is unknown how the dummy's directional sensitivity relates to the human experience.

While the pendulum tests show that directional sensitivity of the dummy's ribcage exists, the directional sensitivity of the SID-IIsFRG in +15 and -15 degree impacts appears comparable to those of other side impact dummies. Further, the loading of the dummy in the pendulum tests is unlike the loading experienced in a vehicle crash test. The pendulum has a small and rigid impact face and a relatively small mass that is intended to load a specific localized region of the dummy. In contrast, in a vehicle crash test, an intruding vehicle structure loads the dummy in multiple areas during a collision. The intruding area is usually fairly large, is typically energy absorbing, and changes its configuration and force of impact direction during the crash. The agency is not aware of vehicle crash test data that provides evidence of consistent increases or decreases in the dummy responses due to oblique loading. Accordingly, while the pendulum tests indicate that the dummy has some

²¹ There are other views as to the need for the improvements to the SID-IIs. Comments to the May 17, 2004, NPRM on FMVSS No. 214 can be viewed in NHTSA Docket 17694.

sensitivity to impact direction, this finding has not been established as being relevant to loading conditions in vehicle tests.

X. Proposed Calibration Tests

The proposed calibration procedures in general follow the test conditions and specifications contained in FTSS's document, "SID-IIs Small Side Impact Crash Test Dummy User's Manual," February 2002. NHTSA used this document as a basis because of FTSS involvement with OSRP in the design and development of the dummy.

Head Drop Test Specifications

The head is dropped from 200 mm onto a flat, rigid steel plate such that the midsagittal plane of the head makes a 35 degree angle with respect to the impact surface while the head's anterior-posterior axis remains horizontal. When the dummy head is dropped in accordance with the above test conditions, the resultant acceleration of the center of gravity of the head must be between 125 and 145 g's. This proposed corridor is narrower than that specified by FTSS for this dummy (115–145 g's). The NHTSA data base, consisting of two heads dropped in a series five impacts each, indicated that the SID-IIsFRG head is capable of meeting the narrower limits.

Neck Pendulum Test

The proposed test procedure involves attaching the dummy's neck-headform assembly to a pendulum fixture. The pendulum is raised to a height from which it falls to achieve a velocity of 5.57 ± 0.06 m/s at the instant the pendulum hits the hexcell deceleration block. Based on tests of two neck-headform assemblies, the agency determined that the neck would limit the headform lateral flexion-rotation between 74 and 79 degrees, and the resistance moment about the occipital condyle from -40 to -45 N-m compared to 72–82 degrees and maximum moment of -36 to -43 N-m suggested in the FTSS user manual.

Thorax

The dummy's thoracic response is ascertained by testing the thorax with the arm and the thorax without the arm. In the tests, the dummy is seated on a specified bench seat. The thorax with arm test calls for the dummy's arm being oriented downward to the lowest detent. A pendulum impactor is guided so as to strike the dummy's arm at 6.7 m/s at the midpoint level of the second rib. The dummy's shoulder rib as well as its upper, middle and lower thorax ribs would have to meet deflection

limits of 28–34 mm, 23–28 mm, 28–33 mm; and 31–36 mm, respectively. In addition, the peak accelerations would have to be 40 to 46 g's at the upper spine (T₁) and 37 to 41 g's at the lower spine (T₁₂). FTSS suggests in its SID-IIs user manual deflection limits for the upper rib of 24–32 mm, for middle rib 26–42 mm, and for the lower rib 34–42 mm, and for accelerations the limits of 35–50 g's for the upper and 22–48 g's for the lower spines. However, while the FTSS suggested limits in general are broader in range they are not directly comparable to the SID-IIsFRG dummy performance values, because of differences in the thorax and shoulder designs between the two dummy types.

The test of the thorax without the dummy's arm is conducted in the same way as the thorax with arm test, except that the stub arm is removed and the impact by the pendulum is at 4.3 m/s. The upper, middle and lower ribs would have to meet the deflection limits of 33 to 39 mm, 38 to 43 mm, and 33–39 mm, respectively, as well as limit the peak acceleration of the upper (T₁) spine between 14 and 18 g's and the lower (T₁₂) spine between 8 and 12 g's. FTSS suggested limits for SID-IIs upper rib deflection is 30–44 mm, for the middle rib 42–58 mm, and for the lower rib 36–52 mm, and accelerations the limits of 13–19 g's for the upper and 8–12g's for the lower spines. As in the thorax test with arms, the FTSS suggested limits in general are broader in range. However, they are not directly comparable to the SID-IIsFRG dummy performance values because of differences in the thorax and shoulder designs between the two dummies.

Abdomen

The abdomen assembly is part of the upper thorax assembly and is represented by two ribs and the deflection sensors. The abdomen test is performed on a seated dummy with the dummy's arm removed. When the dummy's abdomen is impacted by a pendulum at 4.3 m/s, the deflection of each abdominal rib would have to be between 36 and 42 mm, and the peak acceleration of the lower spine (T₁₂) laterally oriented accelerometer range between 11 g's and 15 g's. FTSS suggested abdominal deflection limits are 42–60 mm for the upper and lower abdominal ribs and 9.5–12 g's for the lower spine (T₁₂). As in thorax tests, the performance limits between the SID-IIs and FRG dummies are not directly comparable, because of differences in their abdomen designs.

Pelvis

This test would be performed on a fully assembled, seated dummy that has a certified pelvis plug meeting the force deflection characteristics specified in the designated pelvis plug drawing (see section VI, *supra*). The dummy pelvis would be impacted laterally by a pendulum at a velocity of 6.7 ± 0.1 m/s. Peak acceleration of the impactor and of the pelvis would have to be within the limits of 45 to 49 g's, and 42 and 46 g's, respectively. Peak force responses of the acetabulum would have to be between 3882 and 4270 N and peak iliac wing force response between 524 and 730 N. Comparable limits suggested in the FTSS user manual for the SID-IIs dummy's impactor and pelvis accelerations are 38–42 g's and 46–60 g's, respectively. As in thorax and abdomen tests, the performance limits between the SID-IIs and FRG dummies are not directly comparable, because of differences in the pelvis plug specifications.

Shoulder

A possible shoulder calibration test is described in the FTSS user manual, *supra*. In it, the dummy's shoulder would have to meet deflection and acceleration limits. However, the agency tentatively believes that a 4.3 m/s calibration test for the shoulder is not necessary because the evaluation of the shoulder appears to be achieved by the thorax with arm test. Both tests produced nearly identical shoulder response values. Comments are requested on this issue.

Rulemaking Analyses and Notices

Executive Order 12866 and DOT Regulatory Policies and Procedures

Executive Order 12866, "Regulatory Planning and Review" (58 FR 51735, October 4, 1993), provides for making determinations whether a regulatory action is "significant" and therefore subject to Office of Management and Budget (OMB) review and to the requirements of the Executive Order. The Order defines a "significant regulatory action" as one that is likely to result in a rule that may:

- (1) Have an annual effect on the economy of \$100 million or more or adversely affect in a material way the economy, a sector of the economy, productivity, competition, jobs, the environment, public health or safety, or State, local, or Tribal governments or communities;
- (2) Create a serious inconsistency or otherwise interfere with an action taken or planned by another agency;

(3) Materially alter the budgetary impact of entitlements, grants, user fees, or loan programs or the rights and obligations of recipients thereof; or

(4) Raise novel legal or policy issues arising out of legal mandates, the President's priorities, or the principles set forth in the Executive Order.

This rulemaking action was not considered a significant regulatory action under Executive Order 12866. This rulemaking action was also determined not to be significant under the Department of Transportation's (DOT's) regulatory policies and procedures (44 FR 11034, February 26, 1979). This document proposes to amend 49 CFR Part 572 by adding design and performance specifications for a 5th percentile adult female side impact dummy that the agency may use in compliance tests of Federal side impact protection standards and other related purposes. If this proposed Part 572 rule becomes final, it would affect only those businesses that choose to manufacture or test with the dummy. It would not impose any requirements on anyone.

The cost of an uninstrumented SID-IIsFRG is \$49,000. Instrumentation would add \$40,470 as specified for Part 572 and compliance purposes. Fully instrumenting the dummy (beyond that specified in this notice) could add up to \$135,088, if full instrumentation were desired by dummy users. Full instrumentation is not required by this NPRM. Because the economic impacts of this proposal are so minimal, no further regulatory evaluation is necessary.

Regulatory Flexibility Act

Pursuant to the Regulatory Flexibility Act (5 U.S.C. 601 *et seq.*, as amended by the Small Business Regulatory Enforcement Fairness Act (SBREFA) of 1996), whenever an agency is required to publish a proposed or final rule, it must prepare and make available for public comment a regulatory flexibility analysis that describes the effect of the rule on small entities (*i.e.*, small businesses, small organizations, and small governmental jurisdictions), unless the head of the agency certifies the rule will not have a significant economic impact on a substantial number of small entities. The Small Business Administration's regulations at 13 CFR Part 121 define a small business, in part, as a business entity "which operates primarily within the United States." (13 CFR 121.105(a)).

We have considered the effects of this rulemaking under the Regulatory Flexibility Act. I hereby certify that the proposed rulemaking action would not

have a significant economic impact on a substantial number of small entities. This action would not have a significant economic impact on a substantial number of small entities because the addition of the test dummy to Part 572 would not impose any requirements on anyone. This rulemaking action by NHTSA does not require anyone to manufacture the dummy or to test vehicles with it.

National Environmental Policy Act

NHTSA has analyzed this proposal for the purposes of the National Environmental Policy Act and determined that it will not have any significant impact on the quality of the human environment.

Executive Order 13132 (Federalism)

Executive Order 13132 requires agencies to develop an accountable process to ensure "meaningful and timely input by State and local officials in the development of regulatory policies that have federalism implications." "Policies that have federalism implications" is defined in the Executive Order to include regulations that have "substantial direct effects on the States, on the relationship between the national government and the States, or on the distribution of power and responsibilities among the various levels of government."

NHTSA has analyzed this proposed amendment in accordance with the principles and criteria set forth in Executive Order 13132. The agency has determined that this proposal does not have sufficient federalism implications to warrant consultation and the preparation of a Federalism Assessment.

Civil Justice Reform

This proposed rule would not have any retroactive effect. Under 49 U.S.C. 30103, whenever a Federal motor vehicle safety standard is in effect, a State may not adopt or maintain a safety standard applicable to the same aspect of performance which is not identical to the Federal standard, except to the extent that the state requirement imposes a higher level of performance and applies only to vehicles procured for the State's use. 49 U.S.C. 30161 sets forth a procedure for judicial review of final rules establishing, amending, or revoking Federal motor vehicle safety standards. That section does not require submission of a petition for reconsideration or other administrative proceedings before parties may file suit in court.

Paperwork Reduction Act

Under the Paperwork Reduction Act of 1995, a person is not required to respond to a collection of information by a Federal agency unless the collection displays a valid control number from the Office of Management and Budget (OMB). This proposed rule would not have any requirements that are considered to be information collection requirements as defined by the OMB in 5 CFR Part 1320.

National Technology Transfer and Advancement Act

Section 12(d) of the National Technology Transfer and Advancement Act of 1995 (NTTAA), Public Law 104-113, section 12(d) (15 U.S.C. 272) directs NHTSA to use voluntary consensus standards in its regulatory activities unless doing so would be inconsistent with applicable law or otherwise impractical. Voluntary consensus standards are technical standards (*e.g.*, materials specifications, test methods, sampling procedures, and business practices) that are developed or adopted by voluntary consensus standards bodies, such as the Society of Automotive Engineers (SAE). The NTTAA directs NHTSA to provide Congress, through OMB, explanations when the agency decides not to use available and applicable voluntary consensus standards.

This proposed rulemaking involves technical standards. The NPRM proposes to use SAE standards in the specifications for the instrumentation of the SID-IIsFRG, which accords with the NTTAA. This proposal would adopt most of the specifications of the SID-IIs which was developed by the private sector, except for the FRG modifications. As explained in this preamble, the agency has tentatively determined that the FRG modifications are needed to assure the durability of the test dummy in crash tests.

Unfunded Mandates Reform Act

Section 202 of the Unfunded Mandates Reform Act of 1995 (UMRA), Public Law 104-4, Federal law requires agencies to prepare a written assessment of the costs, benefits, and other effects of proposed or final rules that include a Federal mandate likely to result in the expenditure by State, local, or tribal governments, in the aggregate, or by the private sector, of more than \$100 million annually (adjusted for inflation with base year of 1995). Before promulgating a NHTSA rule for which a written statement is needed, section 205 of the UMRA generally requires the agency to identify and consider a

reasonable number of regulatory alternatives and adopt the least costly, most cost-effective, or least burdensome alternative that achieves the objectives of the rule.

This proposed rule would not impose any unfunded mandates under the UMRA. This proposed rule would not meet the definition of a Federal mandate because it would not impose requirements on anyone. It would amend 49 CFR Part 572 by adding design and performance specifications for a side impact dummy that the agency may use in the Federal motor vehicle safety standards. If this proposed rule becomes final, it would affect only those businesses that choose to manufacture or test with the dummy. It would not result in costs of \$100 million or more to either State, local, or tribal governments, in the aggregate, or to the private sector.

Plain Language

Executive Order 12866 requires each agency to write all rules in plain language. Application of the principles of plain language includes consideration of the following questions:

- Has the agency organized the material to suit the public's needs?
- Are the requirements in the rule clearly stated?
- Does the rule contain technical language or jargon that is not clear?
- Would a different format (grouping and order of sections, use of headings, paragraphing) make the rule easier to understand?
- Would more (but shorter) sections be better?
- Could the agency improve clarity by adding tables, lists, or diagrams?
- What else could the agency do to make this rulemaking easier to understand?

If you have any responses to these questions, please include them in your comments on this NPRM.

Regulation Identifier Number

The Department of Transportation assigns a regulation identifier number (RIN) to each regulatory action listed in the Unified Agenda of Federal Regulations. The Regulatory Information Service Center publishes the Unified Agenda in April and October of each year. You may use the RIN contained in the heading at the beginning of this document to find this action in the Unified Agenda.

Public Participation

How Do I Prepare and Submit Comments?

Your comments must be written and in English. To ensure that your

comments are correctly filed in the Docket, please include the docket number of this document in your comments.

Your comments must not be more than 15 pages long. (49 CFR 553.21). NHTSA established this limit to encourage you to write your primary comments in a concise fashion. However, you may attach necessary additional documents to your comments. There is no limit on the length of the attachments.

Please submit two copies of your comments, including the attachments, to Docket Management at the address given above under **ADDRESSES**.

You may also submit your comments to the docket electronically by logging onto the Dockets Management System Web site at <http://dms.dot.gov>. Click on "Help & Information" or "Help/Info" to obtain instructions for filing the document electronically.

How Can I Be Sure That My Comments Were Received?

If you wish Docket Management to notify you upon its receipt of your comments, enclose a self-addressed, stamped postcard in the envelope containing your comments. Upon receiving your comments, Docket Management will return the postcard by mail.

How Do I Submit Confidential Business Information?

If you wish to submit any information under a claim of confidentiality, you should submit three copies of your complete submission, including the information you claim to be confidential business information, to the Chief Counsel, NHTSA, at the address given above under **FOR FURTHER INFORMATION CONTACT**. In addition, you should submit two copies, from which you have deleted the claimed confidential business information, to Docket Management at the address given above under **ADDRESSES**. When you send a comment containing information claimed to be confidential business information, you should include a cover letter setting forth the information specified in our confidential business information regulation. (49 CFR Part 512.)

Will the Agency Consider Late Comments?

NHTSA will consider all comments that Docket Management receives before the close of business on the comment closing date indicated above under **DATES**. To the extent possible, the agency will also consider comments that Docket Management receives after that

date. If Docket Management receives a comment too late for the agency to consider it in developing a final rule (assuming that one is issued), the agency will consider that comment as an informal suggestion for future rulemaking action.

How Can I Read the Comments Submitted by Other People?

You may read the comments received by Docket Management at the address given above under **ADDRESSES**. The hours of the Docket are indicated above in the same location.

You may also see the comments on the Internet. To read the comments on the Internet, take the following steps:

1. Go to the Docket Management System (DMS) Web page of the Department of Transportation (<http://dms.dot.gov/>).
 2. On that page, click on "search."
 3. On the next page (<http://dms.dot.gov/search/>), type in the four-digit docket number shown at the beginning of this document. Example: If the docket number were "NHTSA-1998-1234," you would type "1234." After typing the docket number, click on "search."
 4. On the next page, which contains docket summary information for the docket you selected, click on the desired comments. You may download the comments. Although the comments are imaged documents, instead of word processing documents, the "pdf" versions of the documents are word searchable.
- Please note that even after the comment closing date, NHTSA will continue to file relevant information in the Docket as it becomes available. Further, some people may submit late comments. Accordingly, the agency recommends that you periodically check the Docket for new material.

Anyone is able to search the electronic form of all comments received into any of our dockets by the name of the individual submitting the comment (or signing the comment, if submitted on behalf of an association, business, labor union, etc.). You may review DOT's complete Privacy Act Statement in the **Federal Register** published on April 11, 2000 (Volume 65, Number 70; Pages 19477-78) or you may visit <http://dms.dot.gov>.

List of Subjects in 49 CFR Part 572

Motor vehicle safety, Incorporation by reference.

In consideration of the foregoing, NHTSA is proposing to amend 49 CFR Part 572 as follows:

PART 572—ANTHROPOMORPHIC TEST DUMMIES

1. The authority citation for Part 572 would continue to read as follows:

Authority: 49 U.S.C. 322, 30111, 30115, 30117 and 30166; delegation of authority at 49 CFR 1.50.

2. 49 CFR part 572 would be amended by adding a new subpart V consisting of §§ 572.190 through 572.198.

The added subpart would read as follows:

Subpart V—SID—IIsFRG Side Impact Crash Test Dummy, 5th Percentile Adult Female

Sec.

572.190 Incorporated materials.

572.191 General description.

572.192 Head assembly.

572.193 Neck assembly.

572.194 Thorax with arm.

572.195 Thorax without arm.

572.196 Abdomen.

572.197 Pelvis.

572.198 Instrumentation and test conditions.

Appendix—Figures to Subpart V of Part 572

Subpart V—SID—IIsFRG Side Impact Crash Test Dummy, 5th Percentile Adult Female

§ 572.190 Incorporated materials.

(a) The following materials are hereby incorporated into this subpart by reference:

(1) A drawings and inspection package entitled “Drawings and Specifications for the SID—IIsFRG Small Female Crash Test Dummy, September 2004”, consisting of:

(i) Drawing No. 180–0000, SID—IIsFRG Dummy Assembly, incorporated by reference in § 572.191;

(ii) Drawing No. 180–1000, Head Assembly, incorporated by reference in §§ 572.191 and 572.192 as part of a complete dummy assembly;

(iii) Drawing No. 180–2000, Neck Assembly, incorporated by reference in §§ 572.191 and 572.193 as part of a complete dummy assembly;

(iv) Drawing No. 180–3000, Upper Torso Assembly, incorporated by reference in §§ 572.191, 572.194, 572.195 and 572.196 as part of a complete dummy assembly;

(v) Drawing No. 180–4000, Lower Torso Assembly, incorporated by reference in §§ 572.191 and 572.197 as part of a complete dummy assembly;

(vi) Drawing No. 180–5000–1, Complete Leg Assembly—left, incorporated by reference in §§ 572.191 and 572.197 as part of a complete dummy assembly;

(vii) Drawing No. 180–5000–2, Complete Leg Assembly—right,

incorporated by reference in §§ 572.191 and 572.197 as part of a complete dummy assembly;

(viii) Drawing No. 180–6000–1, Arm Assembly—left, incorporated by reference in §§ 572.191 and 572.194 as part of a complete dummy assembly;

(ix) Drawing No. 180–6000–2, Arm Assembly—right, incorporated by reference in §§ 572.191 and 572.194 as part of a complete dummy assembly;

(x) the “Parts/Drawing List, Part 572 Subpart V, SID-IIs with Floating Rib Guides (SID-IIsFRG),” September 2004, incorporated by reference in § 572.191;

(2) A procedures manual entitled “Procedures for Assembly, Disassembly and Inspection (PADI) of the SID—IIsFRG Side Impact Crash Test Dummy, October 2004,” incorporated by reference in § 572.191;

(3) SAE Recommended Practice J211, Rev. Mar 95 “Instrumentation for Impact Tests—Part 1—Electronic Instrumentation”;

(4) SAE J1733 of 1994–12 “Sign Convention for Vehicle Crash Testing”.

(b) The Director of the Federal Register approved the materials incorporated by reference in accordance with 5 U.S.C. 552(a) and 1 CFR part 51. Copies of SAE Recommended Practice J211 and SAE J1733 may be inspected at NHTSA’s Technical Reference Library, 400 Seventh Street SW., Room 5109, Washington, DC. Copies of the drawing and inspection package and the PADI may be inspected in the Docket, or at the National Archives and Records Administration (NARA). For information on the availability of this material at NARA, call 202–741–6030, or go to: http://www.archives.gov/federal_register/code_of_federal_regulations/ibr_locations.html.

(c) The incorporated materials are available as follows:

(1) The Drawings and Specifications for the SID—IIsFRG Small Female Crash Test Dummy, September 2004, referred to in paragraph (a)(1) of this section are available in electronic format through the DOT docket management system and in paper format from Leet-Melbrook, Division of New RT, 18810 Woodfield Road, Gaithersburg, MD 20879, (301) 670–0090.

(2) The SAE materials referred to in paragraphs (a)(3) and (a)(4) of this section are available from the Society of Automotive Engineers, Inc., 400 Commonwealth Drive, Warrendale, PA 15096.

§ 572.191 General description.

(a) The SID—IIsFRG Side Impact Crash Test Dummy, small female, is defined

by drawings and specifications containing the following materials:

(1) Technical drawings and specifications package P/N 180–0000, dated September 2004, the titles of which are listed in Table A;

TABLE A

Component assembly	Drawing number
Head Assembly	180–1000
Neck Assembly	180–2000
Upper Torso Assembly	180–3000
Lower Torso Assembly	180–4000
Leg Assembly—left	180–5000–1
Leg Assembly—right	180–5000–2
Arm Assembly—left	180–6000–1
Arm Assembly—right	180–6000–2

(2) The “Parts/Drawing List, Part 572 Subpart V, SID-IIs with Floating Rib Guides (SID-IIs FRG, Alpha Version),” dated September 2004 and containing 8 pages,

(3) A listing of available transducers-crash test sensors for the SID—IIsFRG Side Impact Crash Test Dummy, 5th percentile female, is shown in drawing 180–0000 sheet 2 of 6, dated September 2004,

(4) “Procedures for Assembly, Disassembly and Inspection (PADI) of the SID—IIsFRG Side Impact Crash Test Dummy, September 2004,”

(5) Sign convention for signal outputs reference document SAE 1733 Information Report, titled “Sign Convention for Vehicle Crash Testing,” dated July 15, 1986.

(b) Exterior dimensions of the SID—IIsFRG Side Impact Crash Test Dummy are shown in drawing 180–0000 sheet 3 of 6, dated September 2004.

(c) Weights and center of gravity locations of body segments are shown in drawing 180–0000 sheet 4 of 6, dated September 2004,

(d) Adjacent segments are joined in a manner such that, except for contacts existing under static conditions, there is no additional contact between metallic elements of adjacent body segments throughout the range of motion.

(e) The structural properties of the dummy are such that the dummy conforms to this Subpart in every respect before use in any test similar to those proposed in Standard 214, Side Impact Protection (49 CFR 571.214).

§ 572.192 Head assembly.

(a) The head assembly consists of the head (drawing 180–1000), and a set of three (3) accelerometers in conformance with specifications in 49 CFR 572.198(c) and mounted as shown in drawing 180–0000 sheet 2 of 6. When tested to the procedure specified in paragraph (b) of

this section, the head assembly shall meet performance requirements specified in paragraph (c) of this section.

(b) *Test procedure.* The head shall be tested according to the procedure specified in 49 CFR 572.112(a).

(c) *Performance criteria.* (1) When the head assembly is dropped in either the right or left lateral incline orientations in accordance with procedure in 572.112(a), the measured peak resultant acceleration shall be between 125 g's and 145 g's;

(2) The resultant acceleration-time curve shall be unimodal to the extent that oscillations occurring after the main acceleration pulse shall not exceed 15% (zero to peak) of the main pulse;

(3) The longitudinal acceleration vector (X direction) shall not exceed 15 g's.

§ 572.193 Neck assembly.

(a) The neck assembly consists of parts shown in drawing 180-2000. For purposes of this test, the neck assembly is mounted within the headform assembly (180-9000) as shown in Figure V1 of this subpart. When subjected to the test procedure specified in paragraph (b) of this section, the neck-headform assembly shall meet the performance requirements specified in paragraph (c) of this section.

(b) *Test procedure.* (1) Soak the assembly in a test environment as specified in 49 CFR 572.198(i);

(2) Attach the neck-headform assembly to the 49 CFR Part 572 pendulum test fixture in either the left or right lateral orientations (Figure 22) as shown in Figure V2 of this subpart, so that the midsagittal plane of the neck-headform assembly is vertical and perpendicular to the plane of motion of the pendulum longitudinal centerline;

(3) Release the pendulum from a height sufficient to achieve a velocity of 5.57 ± 0.06 m/s measured at the center of the pendulum accelerometer, as shown in 49 CFR Part 572 Figure 15, at the instant the pendulum makes contact with the decelerating mechanism;

(4) The neck flexes without the neck-headform assembly making contact with any object;

(5) Time zero is defined as the time of initial contact between the pendulum mounted striker plate and the pendulum deceleration mechanism;

(6) Allow a period of at least thirty (30) minutes between successive tests on the same neck assembly.

(c) *Performance Criteria.* (1) The pendulum deceleration pulse is characterized in terms of decrease in velocity as obtained by integrating the

pendulum acceleration output from time zero:

Time (ms)	Pendulum Delta-V (m/s)
10.0	-2.20 to -2.80
15.0	-3.40 to -4.10
20.0	-4.50 to -5.40
25.0	-5.50 to -6.10
25.0 to 100	-5.20 to -6.20

(2) The maximum translation-rotation of the midsagittal plane of the headform disk (180-9061 or 9062) in the lateral direction measured, with the rotation transducer specified in 49 CFR 572.198(d) shall be 74 to 79 degrees with respect to the longitudinal axis of the pendulum occurring between 50 and 70 ms from time zero;

(3) Peak occipital condyle moment shall not be higher than -40 Nm and not lower than -45 Nm. The moment measured by the neck upper load cell (Mx) shall be adjusted by the following formula: $Mx(oc)^1 = Mx + 0.01778Fy$,

(4) The decaying moment shall cross the 0 Nm line after peak moment 113ms-123 ms after time zero.

§ 572.194 Thorax with arm.

(a) The thorax is part of the upper torso assembly shown in drawing 180-3000. For the "thorax with arm" impact test, the dummy is tested as a complete assembly (drawing 180-0000). The dummy's thorax is equipped with T1 and T12 laterally oriented accelerometers as specified in 49 CFR 572.198(c), and with deflection potentiometers for the thorax and shoulder as specified in 180-3861 and 180-3860, respectively, installed as shown in drawing 180-0000 sheet 2 of 6. When subjected to the test procedure as specified in paragraph (b) of this section, the thorax shall meet performance requirements of paragraph (c) of this section.

(b) *Test procedure.* (1) Soak the dummy assembly (180-0000) in a test environment as specified in 49 CFR 572.198(i);

(2) Seat the dummy, outfitted with the torso jacket (180-3450) and cotton underwear pants, as shown in Figure V3 of this subpart, on a certification bench, specified in Figure V4 of this subpart, with the seat pan and the seatback surfaces covered with a 2 mm thick PTFE (Teflon) sheet;

(3) Align the impact side of the seated dummy tangent to a vertical plane located within 25 mm of the side edge of the bench and set the midsagittal

plane of the dummy to a vertical orientation.

(4) Push the dummy at the knees and at the upper torso with just sufficient horizontally oriented force towards the seat back until its buttocks and the back of the upper torso are in contact with the seat back. The top of the shoulder rib mount (drawing 180-3352) orientation in the fore-and-aft direction is 24.6 ± 1.0 degrees relative to horizontal.

(5) Lower the legs such that the thighs touch the seat pan, the inner part of the right and left legs at the knees are in contact with each other, the heels touch the designated support surface and the feet are vertical and as close together as possible;

(6) The dummy's thoracic lateral reference surface is 0 ± 1 degree relative to horizontal as shown in Figure V3 of this subpart;

(7) Orient the arm downward to the lowest detent;

(8) The impactor is specified in 49 CFR 572.198(a);

(9) The impactor is guided, if needed, so that at contact with the dummy's arm, its longitudinal axis is within ± 1 degree of a horizontal plane and perpendicular to the midsagittal plane of the dummy. The centerpoint of the impactor face is within 2 mm of the vertical midpoint of the second thoracic rib and coincident with a line parallel to the seat back incline passing through the center of the shoulder yoke assembly arm pivot (drawing 180-3327), as shown in Figure V3 of this subpart;

(10) The dummy's arm is impacted at 6.7 ± 0.1 m/s.

(c) *Performance criteria.* (1) While the impactor is in contact with the dummy's arm, the thoracic ribs and the shoulder shall conform to the following range of deflections:

(i) Shoulder not less than 28 mm and not more than 34 mm;

(ii) Upper thorax rib not less than 23 mm and not more than 28 mm;

(iii) Middle thorax rib not less 28 mm and not more than 33 mm;

(iv) Lower thorax rib not less than 31 mm and not more than 36 mm;

(2) Peak acceleration of the upper spine (T1) shall not be less than 40 g's and not more than 46 g's and of the lower spine (T12) not less than 37 g's and not more than 41 g's;

(3) Peak impactor acceleration shall be not less than 30 g's and not more than 36 g's.

§ 572.195 Thorax without arm.

(a) The thorax is part of the upper torso assembly shown in drawing 180-3000. For this thorax test, the dummy is tested as a complete assembly (drawing

¹ $Mx(oc)$ is the moment at occipital condyle and Fy is the lateral shear force measured by the load cell.

180-0000) with the arm (180-6000) removed. The dummy's thorax is equipped with T1 and T12 laterally oriented accelerometers as specified in 49 CFR 572.198(c) and with deflection potentiometers for the thorax as specified in drawing 180-3861, installed as shown in drawing 180-0000 sheet 2 of 6. When subjected to the test procedure specified in paragraph (b) of this section, the thorax shall meet the performance requirements set forth in paragraph (c) of this section.

(b) *Test procedure.* (1) Soak the dummy assembly (180-0000) in a test environment as specified in 49 CFR 572.198(i);

(2) Seat the dummy, outfitted with the torso jacket (180-3450) and cotton underwear pants, as shown in Figure V5 of this subpart, on a certification bench, specified in Figure V4 of this subpart, with the seat pan and the seatback surfaces covered with a 2 mm thick PTFE (Teflon) sheet;

(3) Align the impact side of the seated dummy tangent to a vertical plane located within 25 mm of the side edge of the bench and set the midsagittal plane of the dummy to a vertical orientation.

(4) Push the dummy at the knees and at the upper torso with just sufficient horizontally oriented force towards the seat back until its buttocks and the back of the upper torso are in contact with the seat back. The top of the shoulder rib mount (drawing 180-3352) orientation in the fore-and-aft direction is 24.6 ± 1.0 degrees relative to the horizontal.

(5) Lower the legs such that the thighs touch the seat pan, the inner part of the right and left legs at the knees are in contact with each other, the heels touch the designated support surface and the feet are vertical and as close together as possible;

(6) The dummy's thoracic lateral reference surface is 0 ± 1 degree relative to the horizontal as shown in Figure V5 of this subpart;

(7) The impactor is specified in 49 CFR 572.198(a);

(8) The impactor is guided, if needed, so that at contact with the thorax, its longitudinal axis is within 1 degree of a horizontal plane and perpendicular to the midsagittal plane of the dummy. The centerpoint of the impactor face is within 2 mm of the vertical midpoint of the second thorax rib and coincident with a line parallel to the seat back incline passing through the center of the shoulder yoke assembly arm pivot (drawing 180-3327), as shown in Figure V5 of this subpart;

(9) The dummy's thorax is impacted at 4.3 ± 0.1 m/s;

(c) *Performance criteria.* (1) While the impactor is in contact with the dummy's thorax, the ribs shall conform to the following range of deflections:

(i) Upper and lower thorax ribs not less than 33 mm and not more than 39 mm;

(ii) Middle thorax rib not less than 38 mm and not more than 43 mm;

(iii) Peak acceleration of the upper spine (T1) shall not be less than 14 g's and not more than 18 g's and of the lower spine (T12) not less than 8 g's and not more than 12 g's.

(iv) Peak impactor acceleration shall not be less than 16 g's and not more than 19 g's.

(2) [Reserved]

§ 572.196 Abdomen.

(a) The abdomen assembly is part of the upper torso assembly (180-3000) and is represented by two ribs (180-3368) and the deflection sensors (180-3861). The abdomen test is conducted on the assembled dummy (180-0000) with the arm (180-6000) on the impacted side removed. The dummy is equipped with a lower spine laterally oriented accelerometer as specified in 49 CFR 572.198(c) and deflection potentiometers specified in drawing 180-3861, installed as shown in sheet 2 of drawing 180-0000. When subjected to the test procedure as specified in paragraph (b) of this section, the abdomen shall meet performance requirements of paragraph (c) of this section.

(b) *Test procedure.* (1) Soak the dummy assembly (180-0000) in a test environment as specified in 49 CFR 572.198(i);

(2) Seat the dummy, outfitted with the torso jacket (180-3450) and cotton underwear pants, as shown in Figure V6 of this subpart, on a certification bench, specified in Figure V4 of this subpart, with the seat pan and the seatback surfaces covered with a 2 mm thick PTFE (Teflon) sheet;

(3) Align the impacted side of the seated dummy tangent to a vertical plane located within 25 mm of the side edge of the bench and set the midsagittal plane of the dummy to a vertical orientation;

(4) Push the dummy at the knees and at the upper torso with just sufficient horizontally oriented force towards the seat back until its buttocks and the back of the upper torso are in contact with the seat back. The top of the shoulder rib mount (drawing 180-3352) orientation in the fore-and-aft direction is 24.6 ± 1.0 degrees relative to the horizontal;

(5) Lower the legs such that the thighs touch the seat pan, the inner part of the

right and left legs at the knees are in contact with each other, the heels touch the designated support surface and the feet are vertical and as close together as possible;

(6) The dummy's thoracic lateral reference surface is within 0 ± 1 degree relative to the horizontal as shown in Figure V6 of this subpart;

(7) The impactor is specified in 49 CFR 572.198(b);

(8) The impactor is guided, if needed, so that at contact with the abdomen, its longitudinal axis is within ± 1 degree of a horizontal plane and perpendicular to the midsagittal plane of the dummy and the centerpoint of the impactor's face is within 2 mm of the vertical midpoint between the two abdominal ribs and coincident with a line parallel to the seat back incline passing through the center of the shoulder yoke assembly arm pivot (drawing 180-3327), as shown in Figure V6 of this subpart;

(9) The dummy's abdomen is impacted at 4.3 ± 0.1 m/s.

(c) *Performance criteria.* (1) While the impact probe is in contact with the dummy's abdomen, the deflection of each abdominal rib shall be not less than 36 mm and not more than 42 mm;

(2) Peak acceleration of the lower spine (T12) laterally oriented accelerometer shall be not less than 11 g's and not more than 15 g's;

(3) Peak impactor acceleration shall be not less than 13 g's and not more than 16 g's.

§ 572.197 Pelvis.

(a) The pelvis is part of the lower torso assembly shown in drawing 180-4000. The pelvis test is conducted on the assembled dummy (drawing 180-0000), with the torso jacket (180-3450) removed. The dummy is equipped with a laterally oriented pelvis accelerometer as specified in 49 CFR 572.198(c), acetabulum load cell SA572-S68, and iliac wing load cell SA572-S66, mounted as shown in sheet 2 of 6 of drawing 180-0000. When subjected to the test procedure as specified in paragraph (b) of this section, the pelvis shall meet performance requirements of paragraph (c) of this section.

(b) *Test procedure.* (1) Soak the dummy assembly (180-0000) in a test environment as specified in 49 CFR 572.198(i);

(2) Seat the dummy, without the torso jacket and cotton underwear pants, as shown in Figure V7 of this subpart, on a certification bench, specified in Figure V4 of this subpart, with the seatpan and the seatback surfaces covered with a 2 mm thick PTFE (Teflon) sheet;

(3) Align the impacted side of the seated dummy tangent to a vertical

plane located within 25 mm of the side edge of the bench and set the midsagittal plane of the dummy to a vertical orientation.

(4) Push the dummy at the knees and at the upper torso with just sufficient horizontally oriented force towards the seat back until its buttocks and the back of the upper torso are in contact with the seat back. The top of the shoulder rib mount (drawing 180-3352) orientation in the fore-and-aft direction is 24.6 ± 1.0 degrees relative to the horizontal.

(5) Lower the legs such that the thighs touch the seat pan, the inner part of the right and left legs at the knees are in contact with each other, the heels touch the designated support surface and the feet are vertical and as close together as possible;

(6) The dummy's thoracic lateral reference surface is within 0 ± 1 degree relative to the horizontal as shown in Figure V7 of this subpart;

(7) The pelvis impactor is specified in 49 CFR 572.198(a);

(8) The impactor is guided, if needed, so that at contact with the pelvis, its longitudinal axis is within ± 1 degree of a horizontal plane and perpendicular to the midsagittal plane of the dummy. The centerpoint of the impactor's face is within 2 mm of the centerline of the screw (9001191) through the center of the acetabulum load cell, as shown in Figure V7 of this subpart;

(9) The dummy's pelvis is impacted at 6.7 ± 0.1 m/s.

(c) *Performance criteria.* While the impactor is contact with the pelvis:

(1) Peak acceleration of the impactor is not less than 45 g's and not more than 49 g's;

(2) Peak acceleration of the pelvis is not less than 42 g's and not more than 46 g's and occurs 5 ms or more after the impactor contacts the dummy;

(3) Peak acetabulum force is not less than 3882 N and not more than 4270 N;

(4) Peak iliac wing force is not less than 524 N and not more than 730 N.

§ 572.198 Instrumentation and test conditions.

(a) The test probe for lateral thorax and pelvis impact tests is the same as that specified in 572.137(a) except that its impact face diameter is 120.70 ± 0.25 mm and it has a minimum mass moment of inertia of 3646 kg-cm²;

(b) The test probe for the lateral abdomen impact test is the same as that specified in 572.137(a) except that its impact face diameter is 76.20 ± 0.25 mm and it has a minimum mass moment of inertia of 3646 kg-cm²;

(c) Accelerometers for the head, the thoracic spine, and the pelvis conform to specifications of SA572-S4;

(d) Rotary potentiometers for the neck-headform assembly conform to SA572-S51;

(e) Instrumentation and sensors conform to the Recommended Practice SAE J-211 (March 1995), Instrumentation for Impact Test, unless noted otherwise;

(f) All instrumented response signal measurements shall be treated to the following specifications:

(1) Head acceleration—Digitally filtered CFC 1000;

(2) Neck-headform assembly translation-rotation—Digitally filtered CFC 60;

(3) Neck pendulum, T1 and T12 thoracic spine and pelvis accelerations—Digitally filtered CFC 180;

(4) Neck forces (for the purpose of occipital condyle calculation) and moments—Digitally filtered at CFC 600;

(5) Pelvis, thorax and abdomen impactor accelerations—Digitally filtered CFC 180;

(6) Acetabulum and iliac wings forces—Digitally filtered at CFC 600;

(7) Shoulder, thorax, and abdomen deflection—Digitally filtered CFC 600.

(g) Mountings for the head, thoracic spine and pelvis accelerometers shall have no resonant frequency within a range of 3 times the frequency range of the applicable channel class;

(h) Leg joints of the test dummy are set at the force between 1 to 2 g's, which just support the limb's weight when the limbs are extended horizontally forward. The force required to move a limb segment does not exceed 2 g's throughout the range of the limb motion.

(i) Performance tests are conducted, unless specified otherwise, at any temperature from 20.6 to 22.2 degrees C. (69 to 72 degrees F.) and at any relative humidity from 10% to 70% after exposure of the dummy to those conditions for a period of 3 hours.

BILLING CODE 4910-59-P

Appendix—Figures to Subpart V of Part 572

Figure V1
NECK ATTACHED TO HEADFORM ASSEMBLY

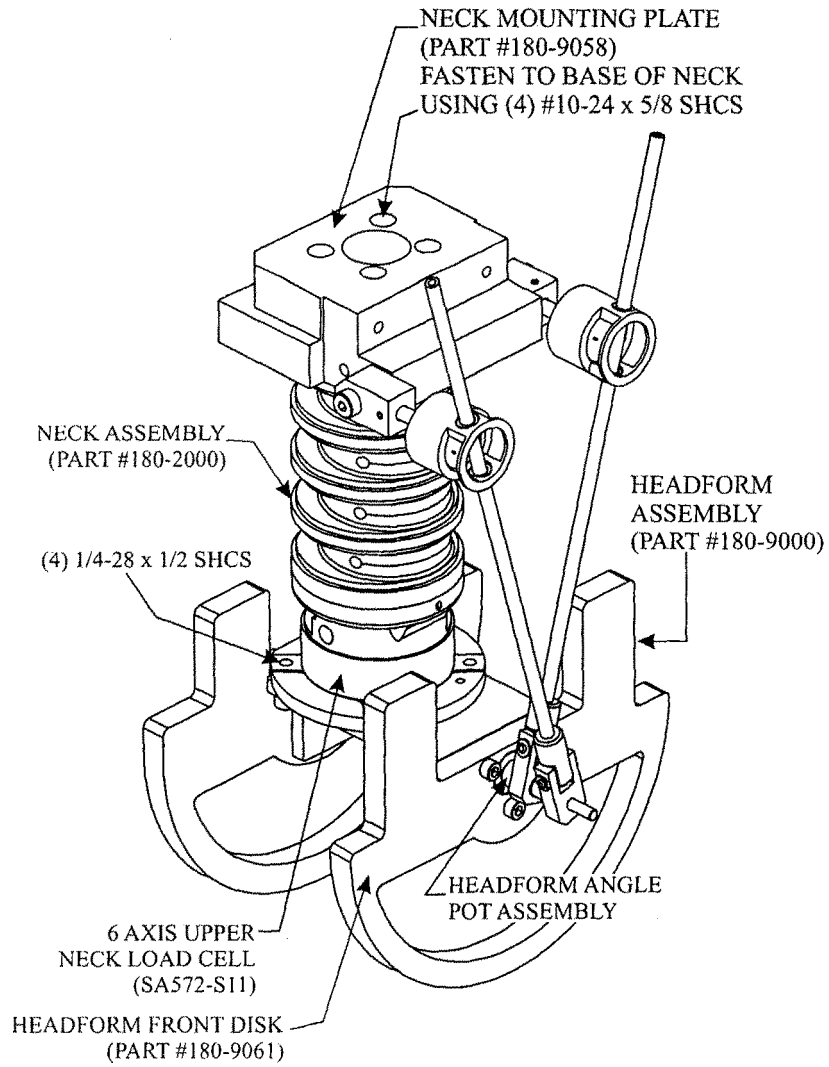

Figure V2-A
NECK/HEADFORM ATTACHED TO PENDULUM
FOR LEFT-SIDE IMPACT

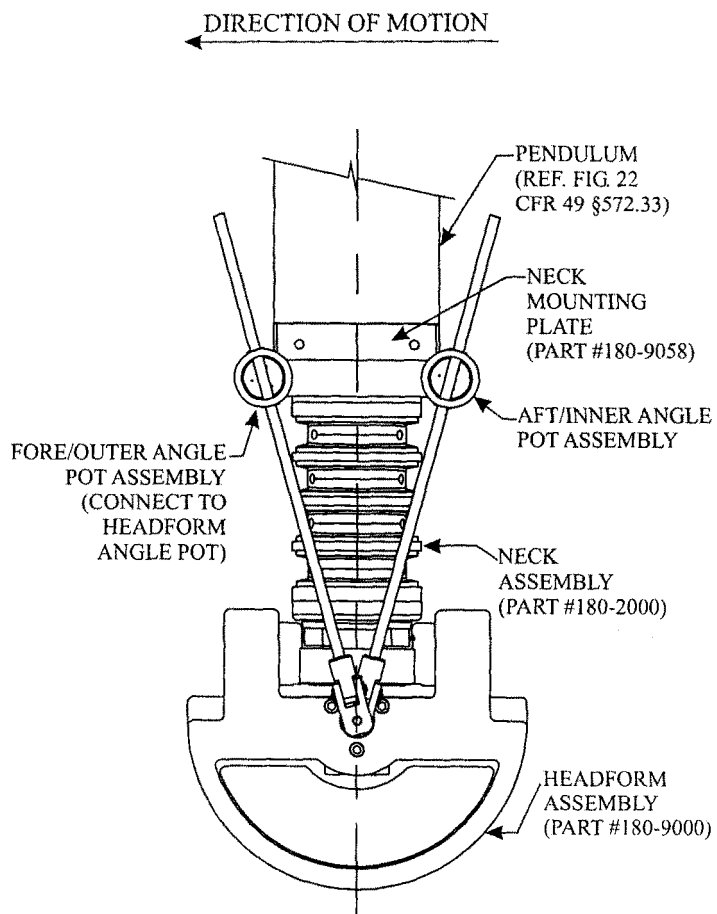

Figure V2-B
NECK/HEADFORM ATTACHED TO PENDULUM
FOR RIGHT-SIDE IMPACT

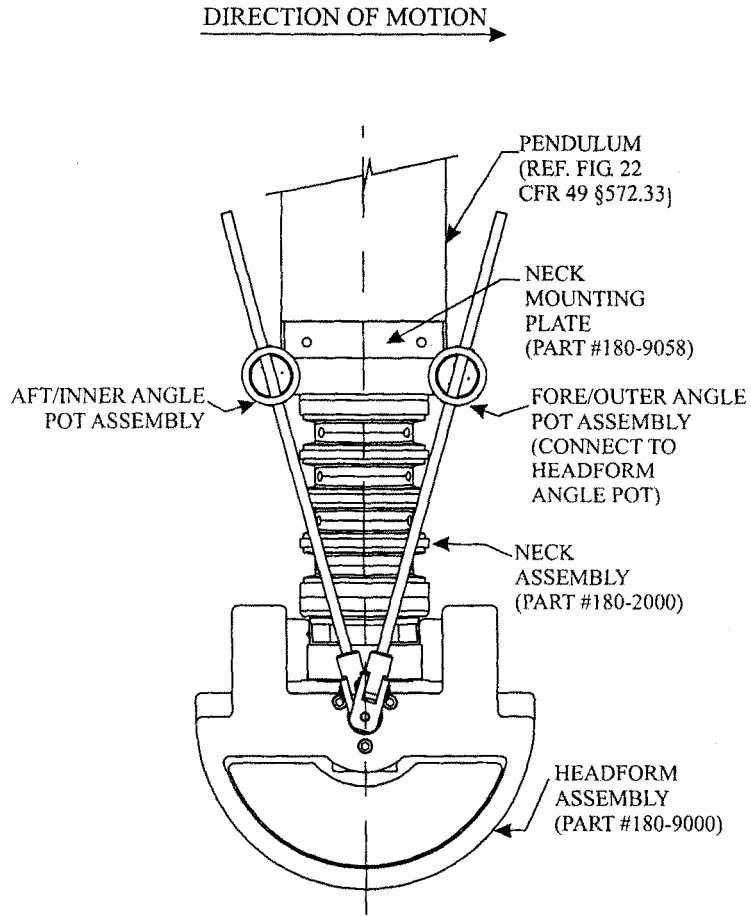

Figure V2-C
ANGLE MEASUREMENTS WITH HEADFORM SET-UP

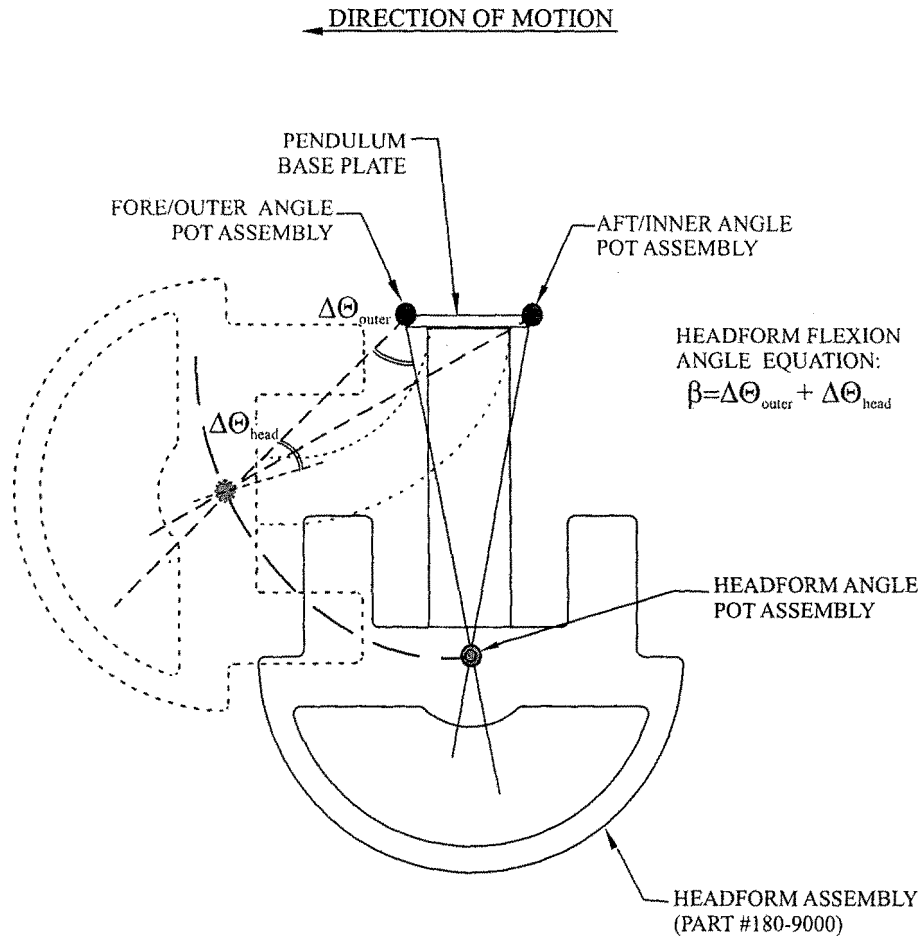

Figure V3
THORAX WITH ARM IMPACT

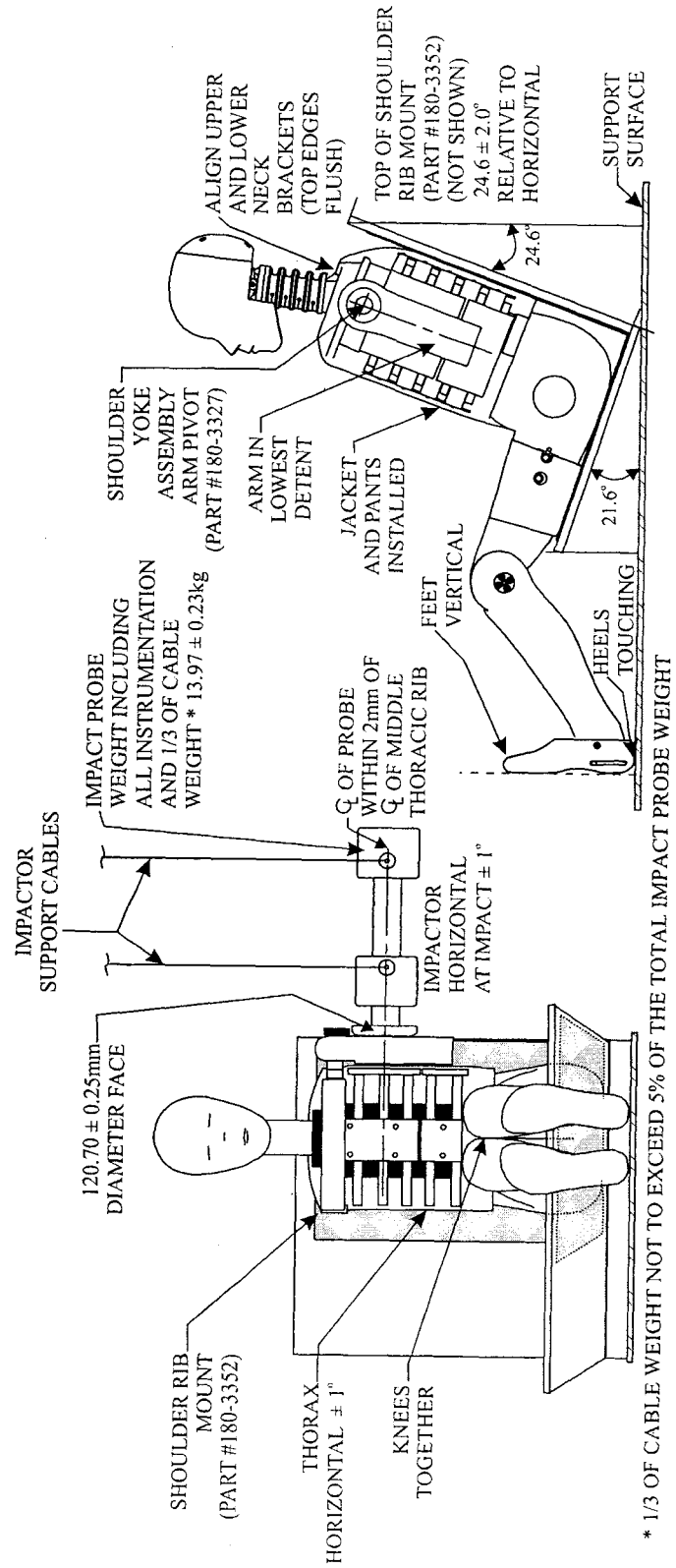

FIGURE V4
CERTIFICATION BENCH

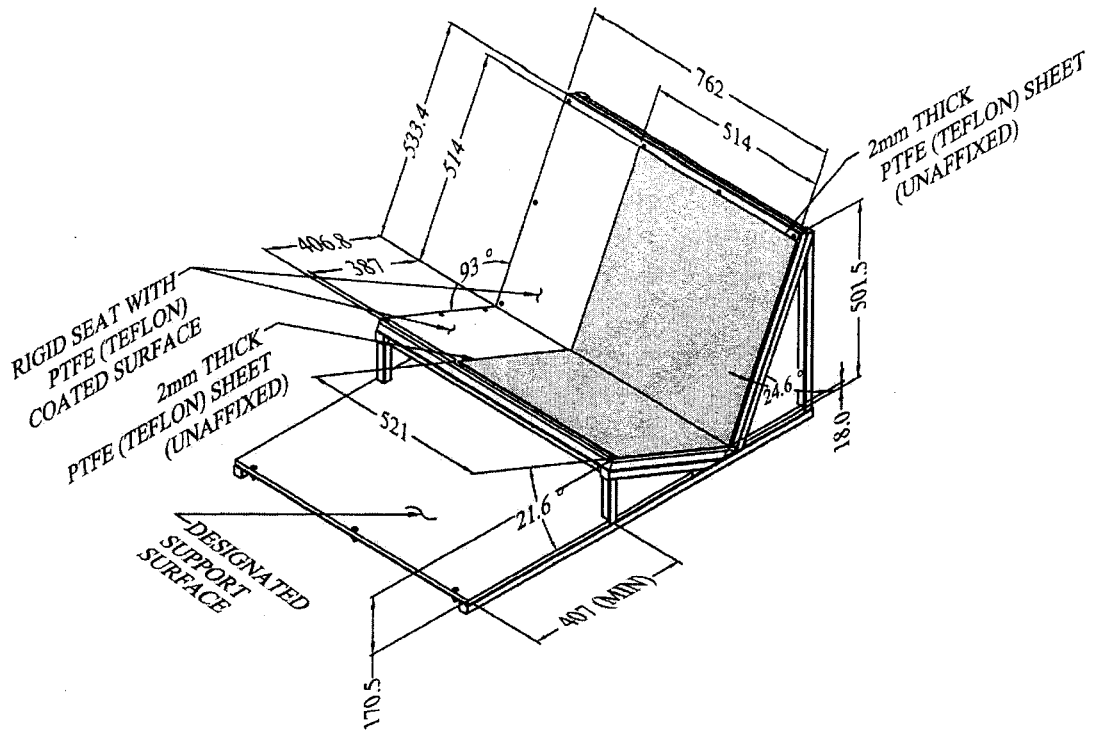

Figure V5
THORAX WITHOUT ARM IMPACT

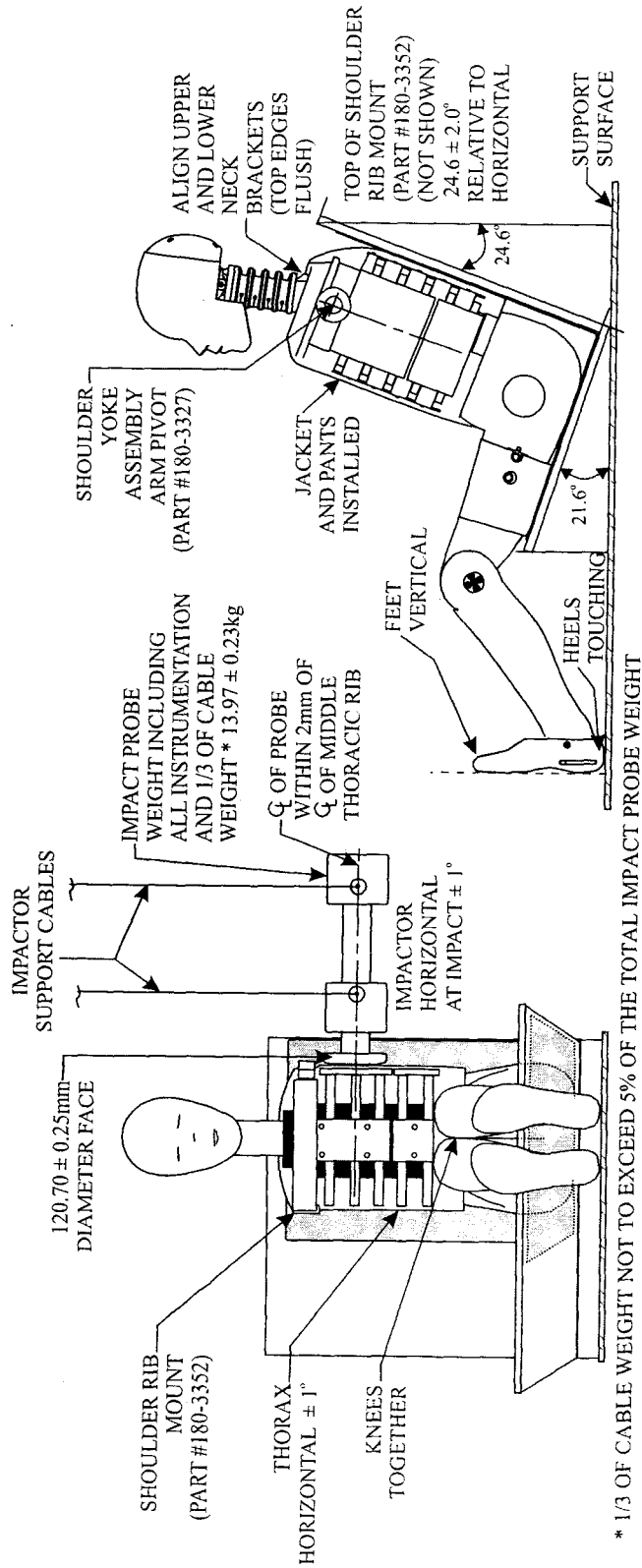

Figure V6
ABDOMEN IMPACT

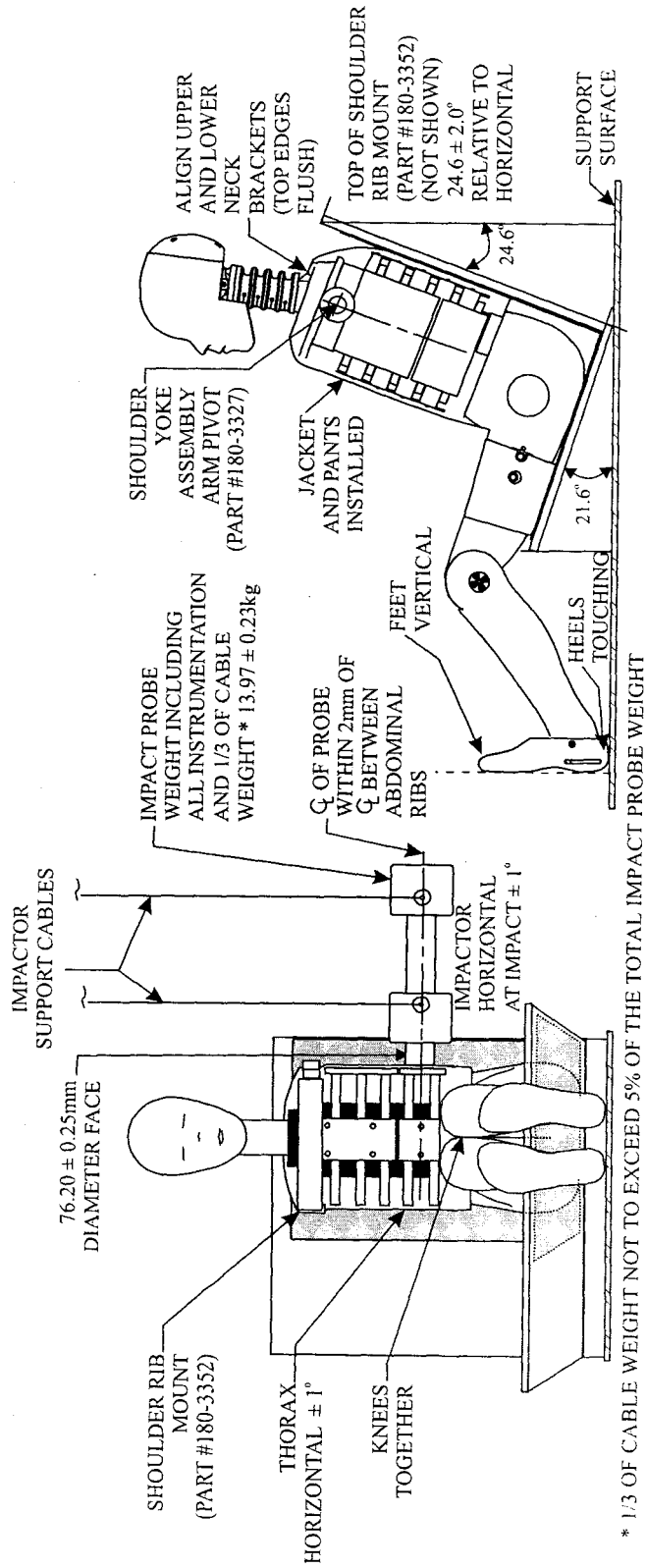
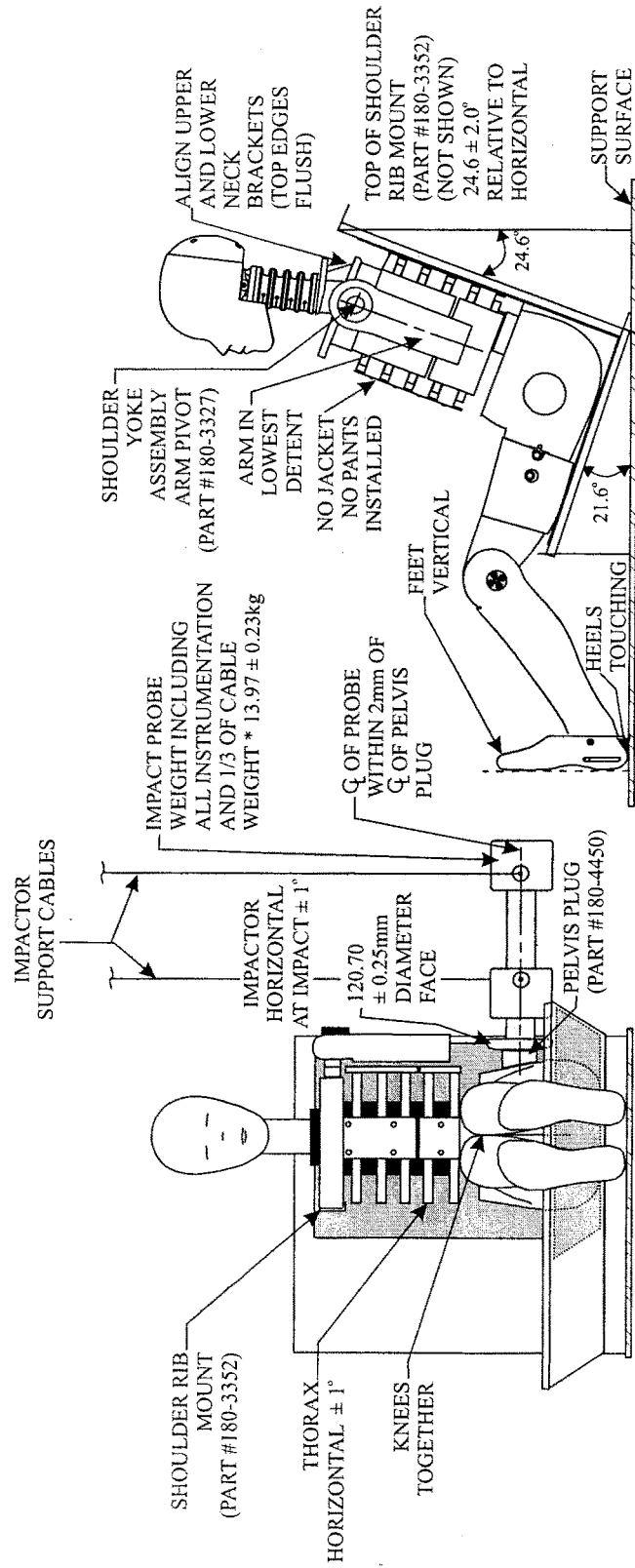

Figure V7
PELVIS IMPACT



* 1/3 OF CABLE WEIGHT NOT TO EXCEED 5% OF THE TOTAL IMPACT PROBE WEIGHT

Issued November 30, 2004.

Stephen R. Kratzke,

Associate Administrator for Rulemaking.

[FR Doc. 04-26753 Filed 12-7-04; 8:45 am]

BILLING CODE 4910-59-C

DEPARTMENT OF THE INTERIOR

Fish and Wildlife Service

50 CFR Part 17

RIN 1018-A178

Endangered and Threatened Wildlife and Plants; Notice of Availability of Draft Economic Analysis and Reopening of the Public Comment Period for the Proposed Designation of Critical Habitat for *Astragalus jaegerianus* (Lane Mountain Milk-vetch)

AGENCY: Fish and Wildlife Service, Interior.

ACTION: Proposed rule; notice of availability of draft economic analysis and reopening of public comment period.

SUMMARY: We, the U.S. Fish and Wildlife Service (Service), announce the availability of a draft economic analysis for the proposed designation of critical habitat for *Astragalus jaegerianus* (Lane Mountain milk-vetch) under the Endangered Species Act of 1973, as amended (Act). We are also reopening the public comment period for the proposal to designate critical habitat for this species to allow all interested parties to comment on the proposed rule and the associated draft economic analysis. Comments previously submitted on the proposed rule need not be resubmitted as they have been incorporated into the public record as part of this reopening of the comment period, and will be fully considered in preparation of the final rule.

DATES: We will accept all comments and information received on or before January 7, 2005. Any comments that we receive after the closing date may not be considered in the final decision on this proposal.

ADDRESSES: If you wish to comment, you may submit your comments and materials concerning this proposed rule by any one of several methods:

(1) You may submit written comments and information to the Field Supervisor, U.S. Fish and Wildlife Service, Ventura Fish and Wildlife Office, 2493 Portola Road, Suite B, Ventura, California 93003, or by facsimile 805/644-3958.

(2) You may hand-deliver written comments to our office, at the address given above.

(3) You may send comments by electronic mail (e-mail) to: fw1Lanemv@r1.fws.gov. Please see the Public Comments Solicited section below for file format and other information about electronic filing. In the event that our Internet connection is not functional, please submit your comments by the alternate methods mentioned above.

Comments and materials received, as well as supporting documentation used in preparation of the proposed critical habitat rule, will be available for public inspection, by appointment, during normal business hours at the above address. You may obtain copies of the draft economic analysis for *Astragalus jaegerianus* by contacting the Ventura Fish and Wildlife Office at the above address. The draft economic analysis and the proposed rule for critical habitat designation are also available on the Internet at <http://ventura.fws.gov/>. In the event that our Internet connection is not functional, please obtain copies of documents directly from the Ventura Fish and Wildlife Office.

FOR FURTHER INFORMATION CONTACT: Connie Rutherford, Ventura Fish and Wildlife Office, at the address listed above (telephone 805/644-1766; facsimile 805/644-3958).

SUPPLEMENTARY INFORMATION:

Public Comments Solicited

We intend any final action resulting from this proposal to be as accurate and as effective as possible. Therefore, we solicit comments or suggestions from the public, other concerned governmental agencies, the scientific community, industry, or any other interested party concerning the economic analysis or the proposed rule to designate critical habitat for *Astragalus jaegerianus* (69 FR 18018, April 6, 2004). We particularly seek comments concerning:

(1) The reasons why any habitat should or should not be determined to be critical habitat as provided by section 4 of the Act, including whether the benefits of exclusion outweigh the benefits of specifying such area as part of the critical habitat;

(2) Specific information on the amount and distribution of *Astragalus jaegerianus* habitat, and what habitat is essential to the conservation of this species and why;

(3) Land use designations and current or planned activities in the subject area and their possible impacts on proposed habitat;

(4) Any foreseeable economic, national security, or other potential impacts resulting from the proposed

designation of critical habitat; in particular, any impacts on small entities or families;

(5) Whether the economic analysis identifies all State and local costs attributable to the proposed critical habitat designation. If not, what costs are overlooked;

(6) Whether the economic analysis makes appropriate assumptions regarding current practices and likely regulatory changes imposed as a result of the designation of critical habitat;

(7) Whether the economic analysis correctly assesses the effect on regional costs associated with land use controls that derive from the designation;

(8) Whether the designation will result in disproportionate economic impacts to specific areas that should be evaluated for possible exclusion from the final designation;

(9) Whether the economic analysis appropriately identifies all costs that could result from the designation; and

(10) Whether our approach to critical habitat designation could be improved or modified in any way to provide for greater public participation and understanding, or to assist us in accommodating public concern and comments.

All comments and information submitted during the initial comment period on the proposed rule need not be resubmitted. If you wish to comment, you may submit your comments and materials concerning the draft economic analysis and proposed rule by any one of several methods (*see ADDRESSES* section).

Please submit Internet comments to fw1Lanemv@r1.fws.gov in an ASCII file format and avoid the use of special characters and encryption. Please also include "Attn: Lane Mountain Milk-vetch Critical Habitat" in your e-mail subject header, and your name and return address in the body of your message. If you do not receive a confirmation from the system that we have received your Internet message, contact us directly by calling our Ventura Fish and Wildlife Office (*see FOR FURTHER INFORMATION CONTACT* section).

Our practice is to make comments, including names and home addresses of respondents, available for public review during regular business hours. Individual respondents may request that we withhold their home addresses from the rulemaking record, which we will honor to the extent allowable by law. There also may be circumstances in which we would withhold from the rulemaking record a respondent's identity, as allowable by law. If you wish for us to withhold your name and/